

Buderus G234X and G334X Series boilers set new standards for service, quality, and efficiency.

Models 73 through 132 come with 2 burner assemblies and 2 gas trains, allowing step firing.

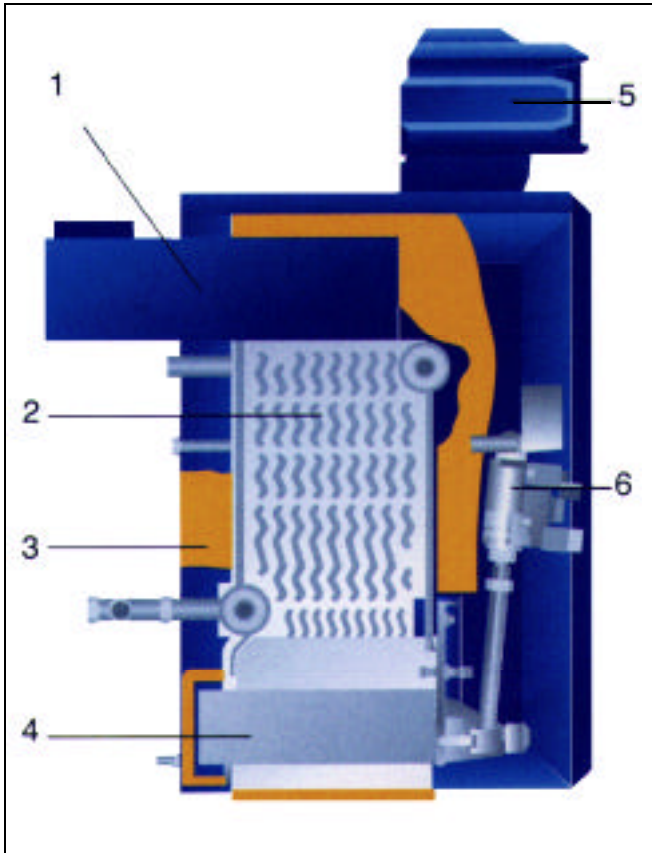

1. Draft hood with integral diverter for dilution of flue gases.
2. Boiler sections: flexible cast iron with contoured fins.
3. Deluxe blue enameled insulated boiler jacket.
4. Stainless steel pre-mix burners with high reliability.
5. Optional Ecomatic control for better comfort and fuel economy.
6. Gas valve with intermittent ignition.

Standard Boiler Features:

- ❑ Manufactured by Buderus, world's leader in cast iron boiler design and production.
- ❑ Flexible GL-180M cast iron, designed to resist thermal shock for long life.
- ❑ High silicone cast iron surface for excellent corrosion resistance.
- ❑ High precision castings with steel push nipples.
- ❑ Staggered contoured fins for optimum heat transfer and efficient operation.
- ❑ Deluxe, heavy-gauge, blue enameled jacket.
- ❑ Full 3" thermal insulation for minimal standby losses.
- ❑ Integral draft diverter for low profile.
- ❑ All U.S. manufactured Honeywell Controls.



A.G.A. Certified for Natural and Propane Gas



Tested for 58 lbs. ASME Working Pressure



C.G.A. Certified for Natural and Propane Gas

Stainless Steel Premixed Burners:

- ❑ Low emissions with Premixed Burner Technology
- ❑ Factory tested for natural gas operation.
- ❑ All models easily converted to propane.
- ❑ Complete burner tray is easily removed.
- ❑ Durable, quiet and efficient, designed for long life.

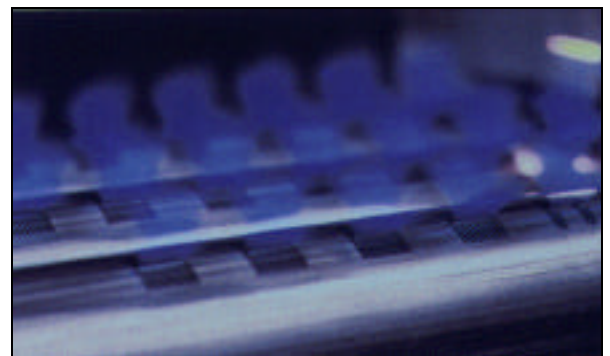

Outstanding features that make the G234X and G334X Series investments that pay off:



Model Features:

- ❑ G234X-packaged boiler.
- ❑ AFUE Ratings over 84%.
- ❑ Attractive and compact design.
- ❑ G334X has two-stage firing capability.
- ❑ All models include 30 PSI relief valve, drain and P&T gauge.

Service Features:

- ❑ Standard non-combustible base.
- ❑ Approved for 2" side clearance to combustibles.
- ❑ Quick disconnect coupling for easy burner removal.
- ❑ All rear tappings for clean, finished appearance.
- ❑ Plug-in connection for vent damper on G234X.

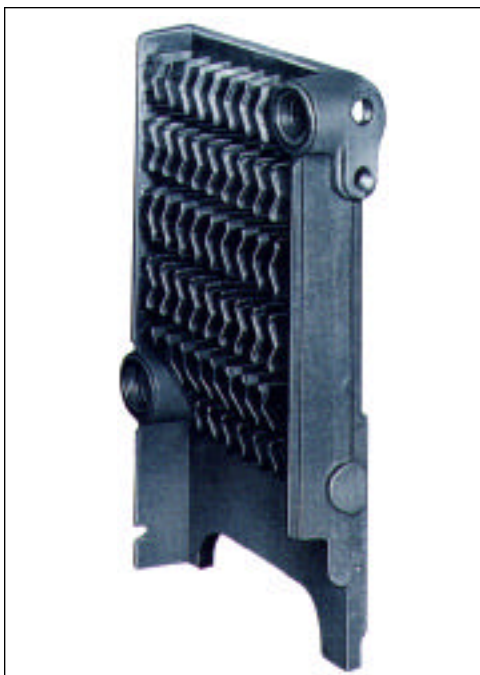

Manufactured from high grade cast iron under strict quality control, the G234X and G334X will provide durability with efficiency.

Delivery and Packing:

- ❑ Boiler sizes 38 to 64
Units completely assembled, jacket installed.
- ❑ Boiler sizes 73 to 132
Sections, burners, and controls assembled; Draft diverter and insulated jacket panel packaged separately.
- ❑ Vent Damper sold separately on larger models.

Shipment of boilers up to model 64 within the U.S.A. include standard vent damper to meet DOE requirements.