

The G124X Series gas boiler set new standards for quality, service, versatility and efficiency.

Versatility:

Two Ignition Options: Intermittent ignition and Standing pilot

Two Venting Options: Atmospheric venting with vent damper or sidewall venting with draft inducer.

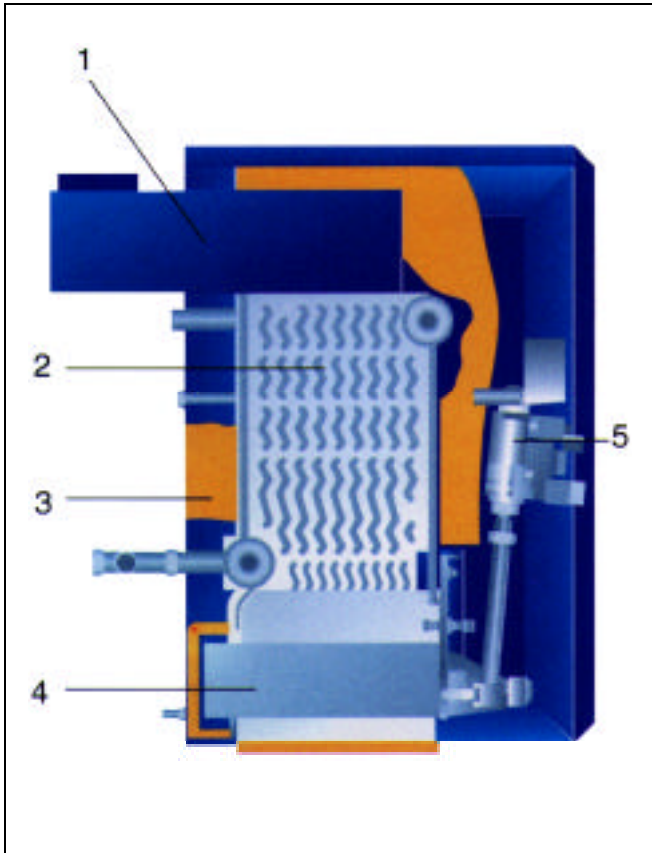

1. Draft hood with integral diverter for dilution of flue gases.
2. Boiler sections: flexible cast iron with contoured fins.
3. Deluxe blue enameled insulated boiler jacket.
4. Stainless steel premix burners with high reliability.
5. Gas valve with intermittent ignition or standing pilot.

Standard Features

- Manufactured by Buderus, world's leader in cast iron boiler design and production.
- Flexible GL-180M cast iron, designed to resist thermal shock for long life.
- High silicone cast iron surface for excellent corrosion resistance.
- High precision castings with threaded steel nipples.
- Staggered, contoured fins for optimum heat transfer and efficient operation.
- Deluxe, heavy gauge blue enameled jacket.
- Full 3" thermal insulation for minimal standby losses.
- U.S.A. factory assembled, wired and tested.
- All U.S. manufactured Honeywell controls.
- Combination slow opening gas control valve.
- Combination circulator relay high limit control.



A.G.A. Certified for
Natural and
Propane Gas



Tested for 58 lbs.
ASME Working
Pressure



C.G.A. Certified for
Natural and
Propane Gas

Stainless Steel Premixed Burners:

- Low emissions with Premixed Burner Technology.
- Factory tested for natural gas operation.
- All models easily converted to propane.
- Complete burner tray is easily removed.
- Durable, quiet and efficient, designed for long life.



Service Features:

- Quick disconnect coupling for easy burner removal.
- U.S.A. factory assembled, wired and tested boiler.
- Approved for installation on combustible flooring.
- Approved for closet installation with 2" clearances.
- All rear tappings for clean, finished appearance.
- Adjustable, rubber leveling feet for ease of installation.
- Standard Honeywell control components.
- Built-in draft diverter for dilution of flue gases.
- 1" supply and return tappings, 1/2" NPT gas connection.

Possible System Upgrades

Indirect fired DHW storage tanks

- Horizontal L-tanks for small foot print.
- Vertical models with improved recovery rates.
- Easy access port for cleaning of tank interior.
- "Duoclean" interior tank protective coating assures corrosion resistance for long life and ease of cleaning.
- Well insulated tank loses less than 1/4°F per hour.
- Large diameter coiled heat exchanger for excellent recovery rates.
- Heat exchanger size increases with tank volume.
- Extra thick Magnesium anode rod for active corrosion protection.
- Optional electric anode.



G124X Series Boiler

Buderus Ecomatic HS2102 and HS3220 control systems

- Low temperature boiler operation for superior comfort and improved fuel efficiency.
- Complete space heating control based on outside temperature with room temperature compensation.
- Priority heating of domestic hot water.
- Adjustable night setback for additional efficiency.
- Adjustable factory heating programs allow customized operation.
- Built-in self diagnostics for ease of service.



HS2102 Ecomatic Control