

PRODUCT INFORMATION PACKET

FASCO®

Model No: D405

Catalog No: D405

1/10 HP OEM Replacement Motor, 3200 RPM, 115 Volts, 3.3" Diameter, SEmi Enclosed
HVAC/R OEM Replacement Motors



Regal and Fasco are trademarks of Regal Beloit Corporation or one of its affiliated companies.
©2019 Regal Beloit Corporation, All Rights Reserved. MC017097E

REGAL



Nameplate Specifications

Output HP	1/10 Hp	Output KW	0.07 kW
Frequency	60 Hz	Voltage	115 V
Current	1.4 A	Speed	3200 rpm
Service Factor	1	Phase	1
Duty	Air Over	Insulation Class	B
Frame	3.3	Enclosure	Open Air Over
Thermal Protection	Thermally Protected	Ambient Temperature	40 °C
UL	Recognized	CSA	Y
CE	N		

Technical Specifications

Electrical Type	Permanent Split Capacitor	Starting Method	Across The Line
Poles	2	Rotation	Reversible
Mounting	Extended Studs	Drive End Bearing	Ball
Opp Drive End Bearing	Ball	Frame Material	Steel
Shaft Type	Flat	Overall Length	7.80 in
Frame Length	4.01 in	Shaft Diameter	0.312 in
Shaft Extension	3.25 in		

This is an uncontrolled document once printed or downloaded and is subject to change without notice. Date Created:29/10/2019

4

3

2

1

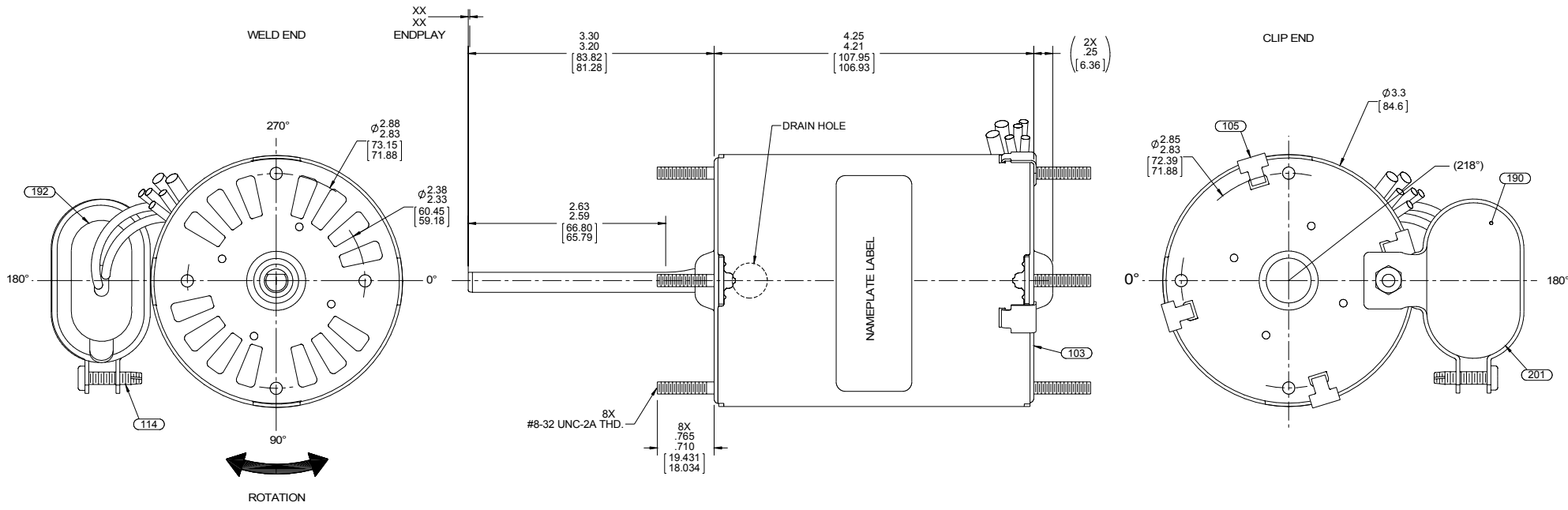

LEAD MATERIAL
18 GA. 4/64 INSUL. 125° C. EPDM
(1) BLK. (1) WHT, 38.00 / 36.00 [965.20/914.40] LONG WITH .56 / .44[14.22/11.18] STRIP.

CAPACITOR LEADS
18 GA. 2/64 INSUL. 125° C. X-LINKED POLY.
(1) BRN, (1) BRN / WHT
8.00 / 6.00 [203.20/152.40] LONG W/FLAG TERM. 89034045 AMP 42742-2

REVERSING LEADS
18 GA. 2/64 INSUL. 125° C. X-LINKED POLY.
(1) BRN, (1) RED, (1) BLU,
(1) YEL. 8.00 / 6.00 [203.20/152.40] LONG TERMINAL HOUSING

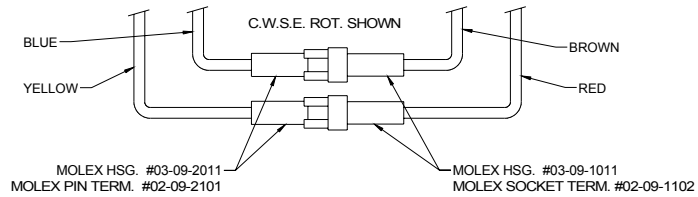

TO REVERSE ROTATION INTERCHANGE RED AND BROWN LEADS
MOTORS MUST HAVE C.W.S.E. CONNECTION WHEN SHIPPING.

NOTES:
108 MOTORS MAXIMUM PER PALLET.
NO PACKAGING TAPE OVER CARTON LABEL.

00464072

00469120

SAFETY WARNING
This motor must be grounded in accordance with local or national electrical codes to prevent possible injury due to electrical shock

AVERTISSEMENT DE SECURITE
Ce moteur doit être fondée sur la réglementation locale ou national électrique codes pour prévenir d'éventuelles blessures en raison de choc électrique

FASCO Fasco Industries, Inc. Motor Division

Assembled in Mexico No. 71620938

115 V 60 Hz Class B
1.4 A 3200 RPM 1/10 HP

Model D405 Sealed Ball Brg

Max. Amb: 40° C

Connection Diagram
C. W. S. E. C. C. W. S. E.

Blk — Line Blk — Line
Wht — Line Wht — Line
Yel — Blu
Red — Red
Blu — Yel
Brn — Brn
Brn — Brn
Brn/Wht — Brn/Wht

4 MFD/370 VAC

CUSTOMER P/N: D405	ENVIRONMENT: WET
CUSTOMER: FASCO DIST.	APPLICATION: -
	MOTOR WEIGHT: 5.25 POUNDS
CUSTOMER APPROVAL	FRONT SHAFT POSITION
SIGNED:	UP DOWN
DATE:	HORIZONTAL
MOTOR TYPE: P.S.C. REFERENCE SAMPLE NUMBER: 71620938	
00 62 30 V 06 BX 5 0 0	
TYPICAL PERFORMANCE AT 208-230 VOLTS 50/60 HZ	
IDLE FULL LOAD LOCKED BREAK	
MOTOR SPEED	RPM AMP WATT IN OZ RPM AMP WATT IN OZ
	3549 .67 57 34.0 3200 1.30 144 18.0 2.89 300 50.0

APPLY IN A CONVENIENT LOCATION TO READ FROM CLIP END

DRAWING REVISION: AJ	REVISION BY: Q.ZHAO	DATE: 07-14-2015	TOLERANCES UNLESS OTHERWISE SPECIFIED: DEC. INCH mm ANGLE X +0.1 [-2.5] ±0.5° XX +0.01 [-0.25] XXX +0.005 [-0.127] XXXX +0.0005 [-0.0127]	DRAWN BY: TAMMY JONES	DATE: 01-07-2002
ECO: ECO-0081097	APPROVED BY: C.ZHANG	DATE: 07-14-2015	REMOVE BURRS & BREAK SHARP EDGES: .0031015 [0.0763811] X 45° CORNER FILLETS: R.02 [51] MACHINED SURFACES: .125 / 3.2 INCH V mm	APPROVED BY:	DESCRIPTION: MODEL-SFHP-3.3 OUTLINE
SEE ECO			THIRD ANGLE PROJECTION	REFERENCE:	MATERIAL: PROCESS/FINISH: BLACK
COPYRIGHT REGAL BELOIT AMERICA, INC. ALL RIGHTS RESERVED. PROPRIETARY AND CONFIDENTIAL INFORMATION. THIS DOCUMENT IS THE PROPERTY OF REGAL BELOIT AMERICA, INC. FURNISHING AND CONTAINING OWNERS PROPRIETARY INFORMATION. ANY PERSON, CORPORATION OR OTHER FIRM RECEIVING IT IS DEEMED, BY RECEIVING IT, TO AGREE THAT IT, AND/OR ANY PART OF IT, SHALL NOT BE DISCLOSED TO ANY PERSON, CORPORATION OR OTHER ENTITY, DUPLICATED, AND/OR USED, EXCEPT AS EXPRESSLY APPROVED IN WRITING IN ADVANCE BY OWNER. THIS DOCUMENT SHALL BE RETURNED TO OWNER UPON REQUEST. IT MAY BE SUBJECT TO CERTAIN RESTRICTIONS UNDER APPLICABLE EXPORT CONTROL LAWS AND REGULATIONS.			INCH V mm	SIZE: C	DRAWING NUMBER: 71620938 SHEET: 1 OF 2

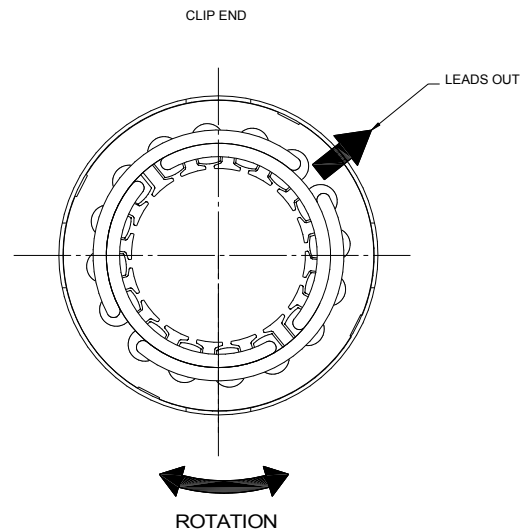
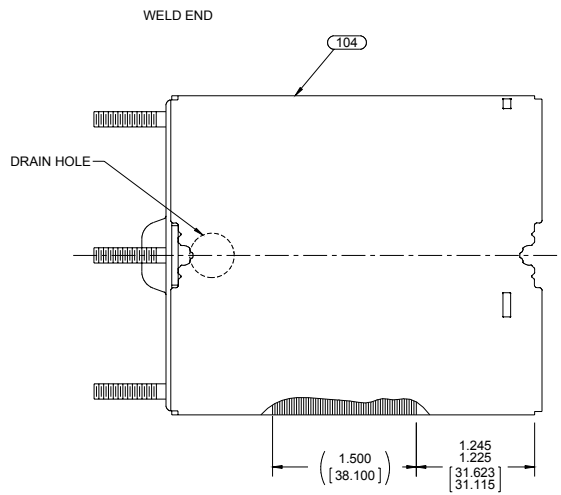

NOTES:

1. STAKE STATOR TO SLEEVE PER P. S. 88830264.
2. MAXIMUM TORQUE REQUIRED TO TURN MOTOR SHAFT IS 3/8 INCH-OUNCE.
3. ASSEMBLE SPRING BETWEEN WASHER AND BEARING ON CLIP END, WITH SPRING FINGERS TOWARD BEARING.
4. ASSEMBLE BALL BEARINGS TO BEARING RETAINERS PER P.S. 8883 4419.
5. ASSEMBLE LOCK WASHER ON WELDBOLT, BETWEEN ENDPLATE AND CAPACITOR BRACKET, PRIOR TO CAPACITOR ASSEMBLY.

PACKING SPECIFICATIONS

1. PACK PER P. S. 8883 4200. 1 PER CONTAINER , 18 CARTONS PER LAYER, 108 PER PALLET, 6 LAYERS PER PALLET.
2. PLACE FOAM RING ON CLIP END OF MOTOR. PLACE FILLER TUBE OVER SHAFT EXTENSION AND PLACE IN CARTON. STUFF PAPER AROUND MOTOR TO PREVENT MOVEMENT DURING SHIPMENT. CLOSE FLAPS AND TAPE.
3. CARTON LABELS MUST ALL FACE ONE DIRECTION TOWARD THE OPEN END OF THE PALLET. SEE P.S. 8883 4408.
4. PLACE ONE FLAT PAD ON PALLET AND ONE BETWEEN EACH
5. PLACE ONE FLAT PAD ON TOP LAYER OF PALLET BEFORE STRETCH WRAPPING. PLACE ALL INSPECTION STICKERS AND WRITING ON FLAT PAD.

DRAWING REVISION AJ	REVISION BY G.ZHAO	DATE 07-14-2015	TOLERANCES UNLESS OTHERWISE SPECIFIED: DEC. INCH mm ANGLE .X ±0.1 [±2.5] ±0.5° .XX ±0.01 [±0.25] .XXX ±0.005 [±0.127] .XXXX ±0.0005 [±0.0127] REMOVE BURRS & BREAK SHARP EDGES: .0031 [0.0762] X 45° CORNER FILLETS: R.02 [51] MACHINED SURFACES: .125 / 3.2 INCH / mm V mm SHOWN IN [BRACKETS]	DRAWN BY TAMMY JONES	DATE 01-07-2002	DESCRIPTION MODEL-SFHP-3.3 OUTLINE
ECO-0081097	APPROVED BY C.ZHANG	DATE 07-14-2015	SEE ECO	APPROVED BY	DATE	MATERIAL
<small>COPYRIGHT REGAL BELOIT AMERICA, INC. ALL RIGHTS RESERVED. PROPRIETARY AND CONFIDENTIAL INFORMATION. THIS DOCUMENT IS THE PROPERTY OF REGAL BELOIT AMERICA, INC. FORMERLY AND CONTAINS OWNER'S PROPRIETARY INFORMATION. ANY PERSON, CORPORATION OR OTHER FIRM RECEIVING IT IS DEEMED BY RECEIVING IT, TO AGREE THAT IT, AND/OR ANY PART OF IT, SHALL NOT BE DISCLOSED TO ANY PERSON, CORPORATION OR OTHER ENTITY, DUPLICATED, AND/OR USED, EXCEPT AS EXPRESSLY APPROVED IN WRITING IN ADVANCE BY OWNER. THIS DOCUMENT SHALL BE RETURNED TO OWNER UPON REQUEST. IT MAY BE SUBJECT TO CERTAIN RESTRICTIONS UNDER APPLICABLE EXPORT CONTROL LAWS AND REGULATIONS.</small>			REFERENCE	THIRD ANGLE PROJECTION	SIZE C	PROCESS/FINISH BLACK
				DRAWING NUMBER 71620938	SHEET 2 OF 2	