



**navien** Condensing Water Heater

# Installation Manual

Model

**NPE-180A/ 210A/ 240A**

**NPE-180S/ 210S/ 240S**



\* Lead Free

Keep this manual near this water heater for future reference whenever maintenance or service is required.

Certified for installation in a manufactured (mobile) home.

**\* The wetted surface of this product contacted by consumable water contains less than one quarter of one percent (0.25%) of lead by weight.**



## WARNING

If the information in these instructions is not followed exactly, a fire or explosion may result, causing property damage, personal injury, or death.

- **Do not store or use gasoline or other flammable vapors and liquids in the vicinity of this or any other appliance.**
- **WHAT TO DO IF YOU SMELL GAS**
  - Do not try to light any appliance.
  - Do not touch any electrical switch; do not use any phone in your building.
  - Immediately call your gas supplier from a neighbor's phone. Follow the gas supplier's instructions.
  - If you cannot reach your gas supplier, call the fire department.
- **Installation and service must be performed by a qualified installer, service agency or the gas supplier.**
- **The installation must conform with local codes or, in the absence of local codes, the National Fuel Gas Code, ANSI Z223.1/NFPA 54 and/or CSA B149.1, Natural Gas and Propane Installation Code.**
- **When applicable, the installation must conform with the Manufactured Home Construction and Safety Standard, Title 24 CFR, Part 3280 and/or CAN/CSA Z240 MH Series, Mobile Homes.**

# Contents

---

|   |           |
|---|-----------|
| <b>1. Safety Information</b>                    | <b>3</b>  |
| <b>2. About the Water Heater</b>                | <b>5</b>  |
| 2.1 Items Included                              | 5         |
| 2.2 Accessories                                 | 5         |
| 2.3 Specifications                              | 6         |
| 2.4 The Front Panel                             | 7         |
| 2.5 Components                                  | 8         |
| 2.6 Dimensions                                  | 10        |
| 2.7 Rating Plate                                | 12        |
| <b>3. Installing the Water Heater</b>           | <b>13</b> |
| 3.1 Choosing an Installation Location           | 13        |
| 3.2 Mounting the Water Heater to the Wall       | 14        |
| 3.3 Connecting the Gas Supply                   | 15        |
| 3.4 Connecting the Water Supply                 | 19        |
| 3.5 Connecting the Condensate Drain             | 25        |
| 3.6 Venting the Water Heater                    | 26        |
| 3.7 Connecting the Power Supply                 | 33        |
| 3.8 Setting the DIP Switches                    | 33        |
| <b>4. Installing a Cascading System</b>         | <b>35</b> |
| 4.1 Connecting Water Supplies                   | 35        |
| 4.2 Connecting the Communication Cables         | 36        |
| <b>5. Appendixes</b>                            | <b>38</b> |
| 5.1 Gas Conversion                              | 38        |
| 5.2 Technical Data                              | 44        |
| 5.3 Wiring Diagram                              | 46        |
| 5.4 Ladder Diagram                              | 48        |
| 5.5 Component Assembly Diagrams and Parts Lists | 50        |
| 5.6 Installation Check list                     | 62        |
| 5.7 Requirements for the State of Massachusetts | 64        |

# 1. Safety Information

---

The following safety symbols are used in this manual. Read and follow all safety instructions in this manual precisely to avoid unsafe operating conditions, fire, explosion, property damage, personal injury, or death.

## DANGER

Indicates an imminently hazardous situation which, if not avoided, could result in severe injury or death.

## WARNING

Indicates a potentially hazardous situation which, if not avoided, could result in injury or death.

## CAUTION

Indicates a potentially hazardous situation that, if not avoided, could result in property damage.

## DANGER



### **If you smell gas:**

- Do not try to light any appliance.
- Do not touch any electrical switches or use landline phones.
- From a neighbor's phone, call your gas provider and follow their instructions.
- If you cannot reach your gas provider, call the fire department.

### **Do not use or store flammable products, such as gasoline, solvents, or adhesives in the same room or area as the water heater.**

- The water heater has a main burner flame that can turn on at any time and can ignite flammable vapors. Vapors from flammable liquids can explode and catch fire, causing death or severe burns.
- Vapors cannot be seen and are heavier than air. They can travel long distances along the ground and can be carried from other rooms to the water heater's main burner flame by air current.
- Keep all flammable products far away from the water heater and store them in approved containers. Keep the containers closed tightly and out of the reach of children and pets.



## WARNING

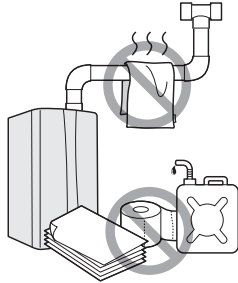

- **Do not store or use gasoline or other flammable liquids near this water heater.**  
Doing so may result in fire or explosion.
- **Do not place combustibles, such as newspapers or laundry, near the water heater or venting system.**  
Doing so may result in a fire.
- **Do not place or use hair sprays, spray paints, or any other compressed gases near the water heater or venting system, including the vent termination.**  
Doing so may result in fire or explosion.
- **Do not operate the water heater with the front cover opened.**  
Doing so may result in fire or carbon monoxide (CO) poisoning, which may result in property damage, personal injury, or death.
- **Do not operate this water heater without proper venting.**  
Doing so may result in fire or carbon monoxide (CO) poisoning, which may result in property damage, personal injury, or death.
- **Do not touch the power cord or internal components of the water heater with wet hands.**  
Doing so may result in electric shock.







## CAUTION

- **Do not turn on the water heater unless the water and gas supplies are fully opened.**  
Doing so may damage the water heater.
- **Do not turn on the water if the cold water supply shut-off valve is closed.**  
Doing so may damage the water heater.
- **Do not use this water heater for anything other than its intended purpose, as described in this manual.**
- **Do not remove the front cover unless the power to the water heater is turned off or disconnected.**  
Failure to do so may result in electric shock.
- **When servicing the controls, label all wires prior to disconnecting them.**  
Failure to do so may result in wiring errors, which can lead to improper or dangerous operation. Verify proper operation after servicing.
- **Do not use unapproved replacement or accessory parts.**  
Doing so may result in improper or dangerous operation and will void the manufacturer's warranty.
- **Do not place anything in or around the vent terminals, such as a clothes line, that could obstruct the air flow in or out of the water heater.**
- **This water heater has been approved for use in the USA and Canada only.**  
Using the water heater in any other country will void the manufacturer's warranty.

## 2. About the Water Heater

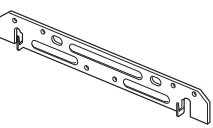
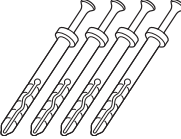
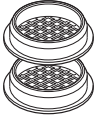
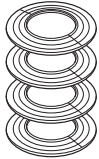

### 2.1 Items Included

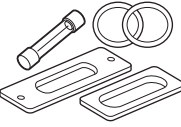
When you open the box, you will find the following items with the water heater. Check the box for each of the following items before installing the water heater.

|   |   |
|---|---|
|    |    |
| Installation & Operation Manual   | Quick Installation Manual   |
|    |    |
| Wall Mounting Bracket   | Tapping Screws & Anchors  |
|  |  |
| 2" Vent Termination Caps  | 2" Wall Flanges   |
|  |  |
| Conversion Kit  | Spare Parts   |

### 2.2 Accessories

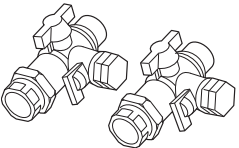
The following optional accessories are available for the water heater:

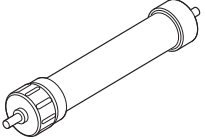
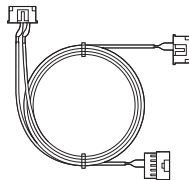
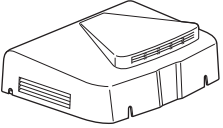
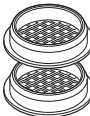
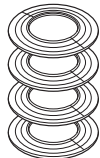
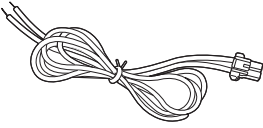
|  |   |
|--|---|
|    |    |
| Remote Controller  | Plumb Easy Valve Set  |
|    |    |
| Pressure Relief Valve  | Condensate Neutralizer  |
|  |  |
| Ready-Link Communication Cable   | Outdoor Vent Kit  |
|  |  |
| 3" Vent Termination Caps   | 3" Wall Flanges   |
|  |   |
| External Pump Connector (<150W,1.5A)   |   |

## 2.3 Specifications

The following table lists the specifications for the water heater. Additional specifications about water, gas, electric, and air supplies (venting) appear in the Installation section.

| Item                                      |                           | NPE-180A  | NPE-180S      | NPE-210A                       | NPE-210S      | NPE-240A                       | NPE-240S      |
|---|---------------------------|---|---------------|--------------------------------|---------------|--------------------------------|---------------|
| Heat Capacity (Input)                     | Natural Gas               | 15,000-150,000 BTU/H  |               | 19,900-180,000 BTU/H           |               | 19,900-199,900 BTU/H           |               |
|   | Propane Gas               | 15,000-150,000 BTU/H  |               | 19,900-180,000 BTU/H           |               | 19,900-199,900 BTU/H           |               |
| Energy Factor                             | Natural Gas               | 0.97  | 0.98          | 0.97                           | 0.98          | 0.97                           | 0.98          |
|   | Propane Gas               | 0.97  | 0.98          | 0.97                           | 0.98          | 0.97                           | 0.98          |
| Flow Rate (DHW)                           | 35°F(19°C) Temp Rise      | 8.4 GPM (32 L/m)  |               | 10.1 GPM (38 L/m)              |               | 11.2 GPM (42 L/m)              |               |
|   | 45°F(25°C) Temp Rise      | 6.5 GPM (25 L/m)  |               | 7.8 GPM (30 L/m)               |               | 8.7 GPM (33 L/m)               |               |
|   | 77°F(43°C) Temp Rise      | 3.8 GPM (14 L/m)  |               | 4.6 GPM (17 L/m)               |               | 5.1 GPM (19 L/m)               |               |
| Dimensions                                |                           | 17.3"(W) x 27.4"(H) x 11.4"(D)  |               | 17.3"(W) x 27.4"(H) x 13.2"(D) |               | 17.3"(W) x 27.4"(H) x 13.2"(D) |               |
| Weight                                    |                           | 75 lbs (34kg)   | 67 lbs (30kg) | 82 lbs (37 kg)                 | 75 lbs (34kg) | 82 lbs (37 kg)                 | 75 lbs (34kg) |
| Installation Type                         |                           | Indoor or Outdoor Wall-Hung   |               |                                |               |                                |               |
| Venting Type                              |                           | Forced Draft Direct Vent  |               |                                |               |                                |               |
| Ignition                                  |                           | Electronic Ignition   |               |                                |               |                                |               |
| Water Pressure                            |                           | 15-150 PSI  |               |                                |               |                                |               |
| Natural Gas Supply Pressure (from source) |                           | 3.5"-10.5" WC   |               |                                |               |                                |               |
| Propane Gas Supply Pressure (from source) |                           | 8"-13" WC   |               |                                |               |                                |               |
| Natural Gas Manifold Pressure (min-max)   |                           | -0.04" WC - -0.84" WC   |               | -0.04" WC - -0.36" WC          |               | -0.04" WC - -0.58" WC          |               |
| Propane Gas Manifold Pressure (min-max)   |                           | -0.03" WC - -0.50" WC   |               | -0.02" WC - -0.66" WC          |               | -0.02" WC - -0.78" WC          |               |
| Minimum Flow Rate                         |                           | 0 GPM (0 L/m)   |               |                                |               |                                |               |
| Connection Sizes                          | Cold Water Inlet          | 3/4" NPT  |               |                                |               |                                |               |
|   | Hot Water Outlet          | 3/4" NPT  |               |                                |               |                                |               |
|   | Gas Inlet                 | 3/4" NPT  |               |                                |               |                                |               |
| Power Supply                              | Main Supply               | 120V AC, 60Hz   |               |                                |               |                                |               |
|   | Maximum Power Consumption | 200W (max 2A), 350W (max 4A) with external pump connected   |               |                                |               |                                |               |
| Materials                                 | Casing                    | Cold Rolled Carbon Steel  |               |                                |               |                                |               |
|   | Heat Exchangers           | Primary Heat Exchanger: Stainless Steel<br>Secondary Heat Exchanger: Stainless Steel  |               |                                |               |                                |               |
| Venting                                   | Exhaust                   | 2" or 3" PVC, CPVC, Polypropylene<br>2" or 3" Special Gas Vent Type BH (Class II, A/B/C)  |               |                                |               |                                |               |
|   | Intake                    | 2" or 3" PVC, CPVC, Polypropylene<br>2" or 3" Special Gas Vent Type BH (Class II, A/B/C)  |               |                                |               |                                |               |
|   | Vent Clearances           | 0" to combustibles  |               |                                |               |                                |               |
| Safety Devices                            |                           | Flame Rod, APS, Ignition Operation Detector, Water Temperature High Limit Switch, Exhaust Temperature High Limit Sensor, Power Surge Fuse |               |                                |               |                                |               |

## 2.4 The Front Panel

The front panel allows you to adjust the water temperature and view the operating status or error codes. Remove the protective sheet from the front panel before using it.

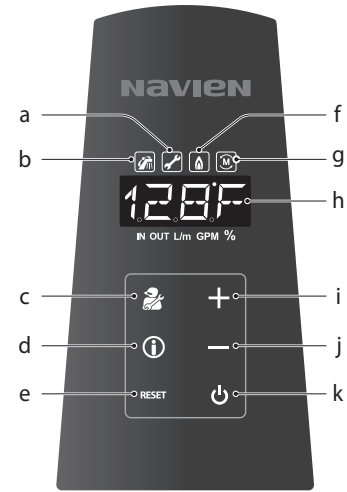

A code will appear on the display



Recirculation Mode



For installers only



Shows basic information



Resets the water heater (When an error occurs)



When the gas burner is on



Cascade operation



Increases the temperature



Decreases the temperature



Turns the water heater on or off

## 2.5 Components

The following diagram shows the key components of the water heater. Component assembly diagrams and particular parts lists are included in the Appendixes.

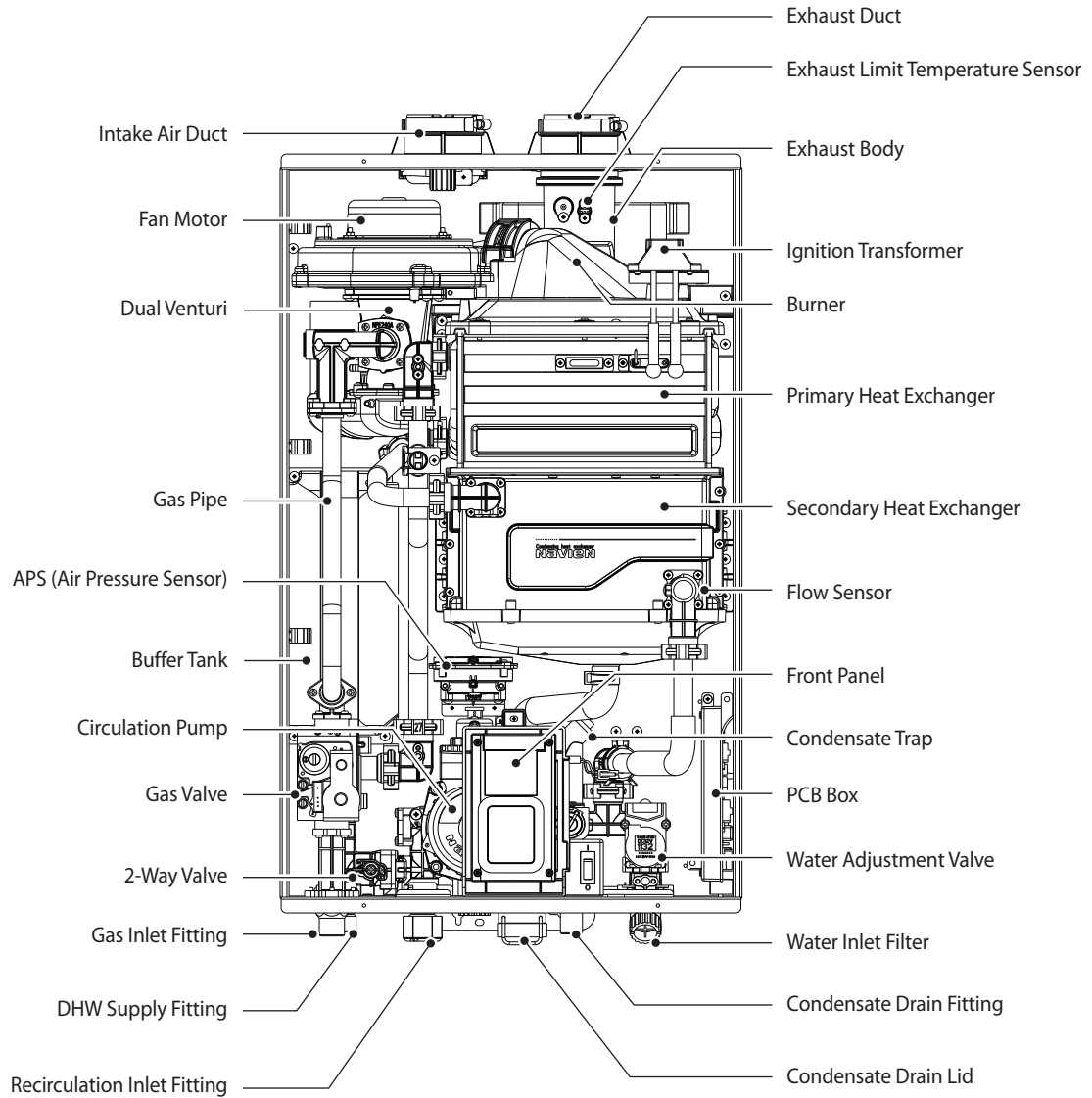

**[NPE-180A/ 210A/ 240A]**

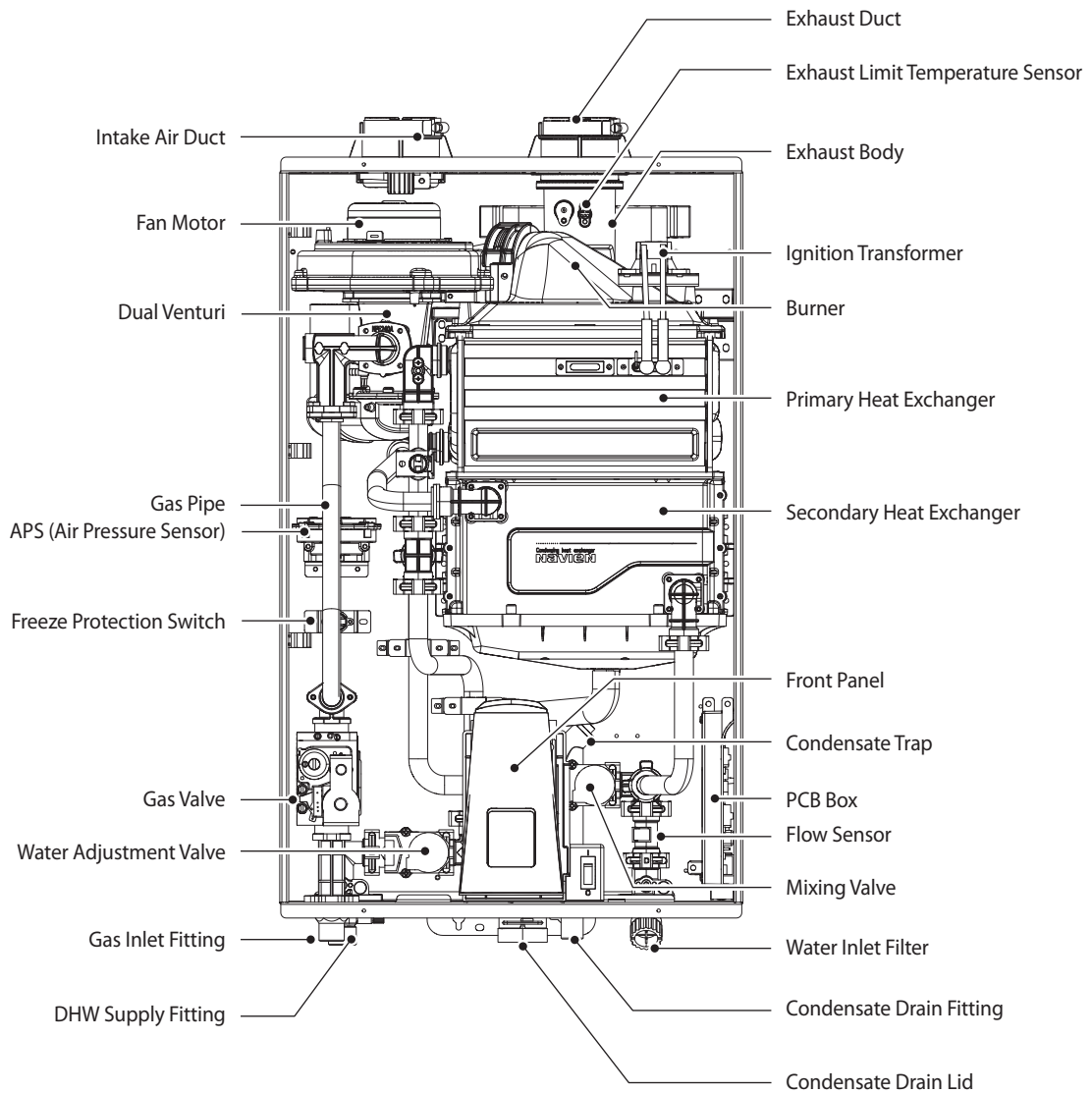

**[NPE-180S/ 210S/ 240S]**

## 2.6 Dimensions

The following diagrams show the dimensions of the water heater and the table lists the supply connections.

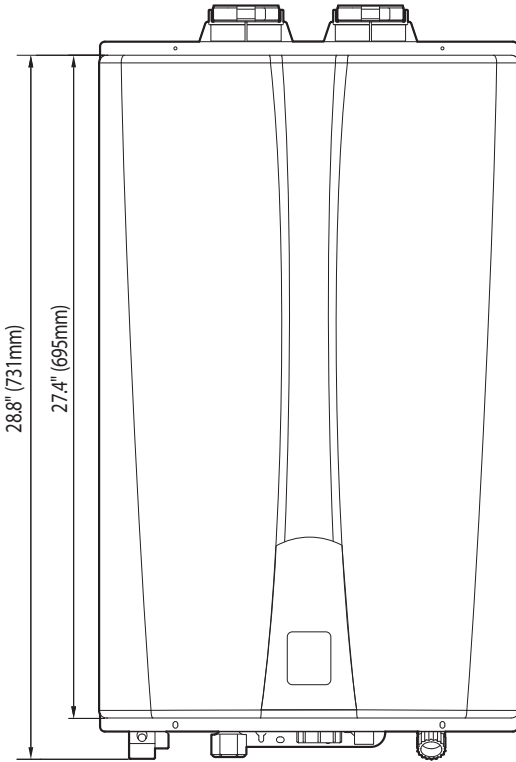

### Supply Connections

|   | Description         | Diameter |
|---|---------------------|----------|
| A | Air Intake          | 2"       |
| B | Exhaust Gas Vent    | 2"       |
| C | Hot Water Outlet    | 3/4"     |
| D | Recirculation Inlet | 3/4"     |
| E | Cold Water Inlet    | 3/4"     |
| F | Gas Inlet           | 3/4"     |
| G | Condensate Outlet   | 1/2"     |

### Overhead View

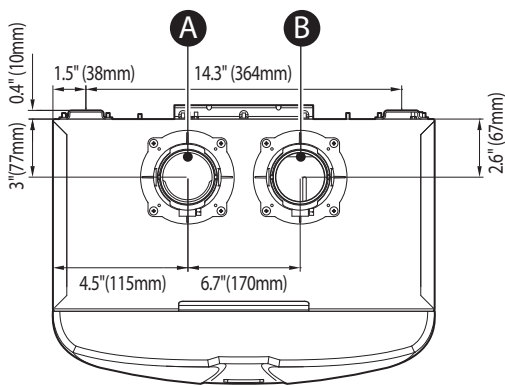

### Supply Connections

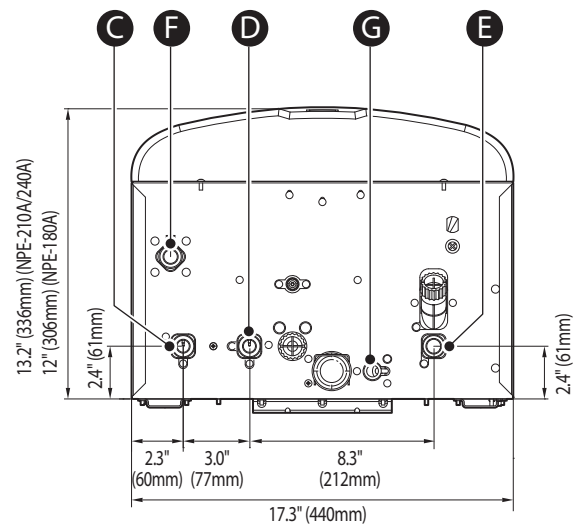

[NPE-180A/ 210A/ 240A]

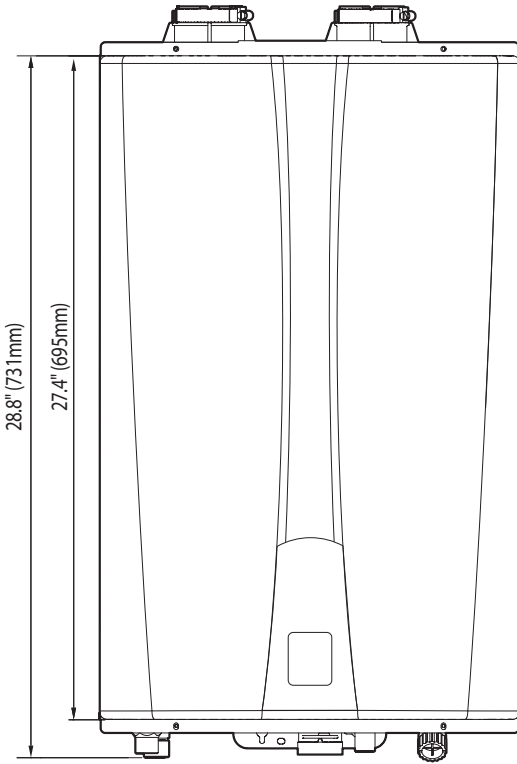

### Supply Connections

|   | Description       | Diameter |
|---|-------------------|----------|
| A | Air Intake        | 2"       |
| B | Exhaust Gas Vent  | 2"       |
| C | Hot Water Outlet  | 3/4"     |
| D | Cold Water Inlet  | 3/4"     |
| E | Gas Inlet         | 3/4"     |
| F | Condensate Outlet | 1/2"     |

### Overhead View

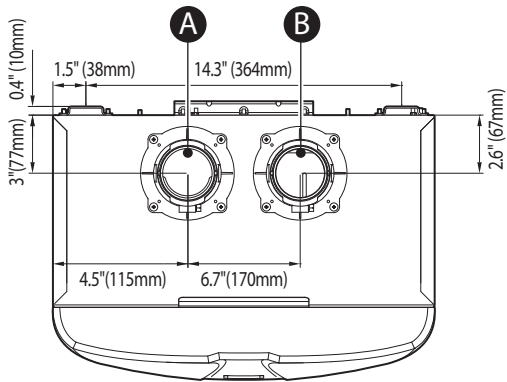

### Supply Connections

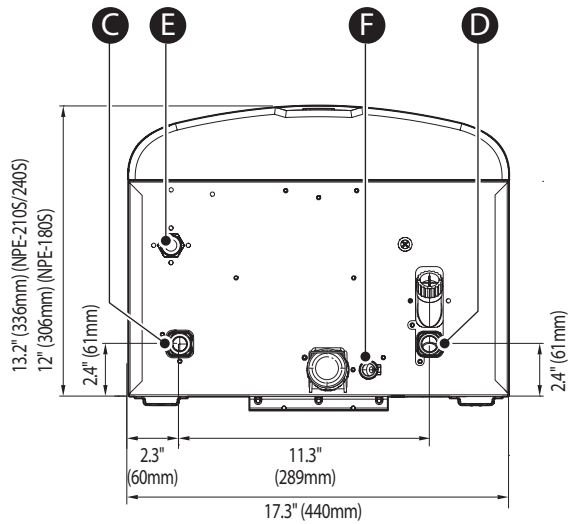

[NPE-180S/ 210S/ 240S]

## 2.7 Rating Plate



Water Heaters come from the factory configured for use with Natural Gas (NG). **Before starting the installation**, check the rating plate located on the side of the water heater to ensure that the water heater matches the gas type, gas pressure, water pressure, and electrical supply available in the installation location. **If the water heater does not match each of these ratings, do not install the water heater.** If conversion to Propane Gas is required, the included gas conversion kit must be used. Refer to “5.1 Gas Conversion” for details.

### Rating Plate, \*Plaque Signalétique

**Direct Vent Automatic Instantaneous Water Heater** \*Chauffe-eau instantané automatique à évent direct  
**For Indoor, Outdoor or Manufactured Home (Mobile Home) Installation** \*Pour installation dans une maison préfabriquée (mobile)

Navien America Inc.  
 20 Goodyear, Irvine, CA 92618  
 Tel: (949) 420 – 0420

|  |  |
|--|--|
| <p><b>Model No.</b>, *Numéro de modèle<br/>NPE-210A</p> <p><b>Max. Input Rating</b>, *Entrée GPL max.<br/>180,000 Btu/h</p> <p><b>Recovery Rating</b>, *Calibre de recouvrement</p> <p><b>Max. Inlet Gas Pressure</b>, *Pression max. de gaz d'entrée</p> <p><b>Min. Inlet Gas Pressure</b>, *Pression min. de gaz d'entrée</p> <p><b>Manifold Pressure</b>, *Pression d'admission</p> <p><b>Electrical Rating</b>, *Régime nominal électrique</p> <p><b>Max. Water Pressure</b>, *Pression d'eau max.</p> | <p><b>Type of Gas</b>, *Type de gaz<br/>NG</p> <p><b>Min. Input Rating</b>, *Débit calorifique max.<br/>19,900 Btu/h</p> <p><b>265 Gallons/Hour</b>, *gallons/heures</p> <p><b>10.5 Inches W.C.</b>, *pouces W.C.</p> <p><b>3.5 Inches W.C.</b>, *pouces W.C.</p> <p><b>-0.36 Inches W.C.</b>, *pouces W.C.</p> <p><b>AC</b> *c.a. <b>120 Volts 60Hz</b>, less than 2 amperes, *Utilise moins de 2A<br/> <b>150 psi</b> *lb/po2    <b>ANSI Z21.10.3 · CSA 4.3-2011</b></p> |
|--|--|

**LOW NOX**  
**emissions**  
complies with SCAQMD rule 1146.2

**Orifices necessary for LP conversion are provided.** \*Les injecteurs nécessaires à la conversion au GPL sont fournis.  
**Failure to use the correct gas can cause problems which can result in death, serious injury or property damage.** \*Le fait de ne pas utiliser le bon gaz peut causer des problèmes qui peuvent mener à la mort, causer des blessures graves ou endommager la propriété.  
**Consult your installation manual for more information.** \*Consultez votre manuel d'installation pour plus d'information.  
**Suitable for combination water (potable) heating and space heating and not suitable for space heating applications only.**  
 \*Convient au chauffage combiné de l'eau (potable) et des locaux, mais non au chauffage des locaux seulement.

This appliance is certified for use at altitudes up to 4,500 ft (1,370 m) in accordance to the latest CAN/CGA 2.17-High Altitude Installation procedures at normal manifold pressure. For installation instructions at altitudes higher than 4,500 ft, please contact Navien. \*Cet appareil est certifié pour une utilisation à des altitudes de 0 à 4,500 pieds (1,370 m) conformément aux toutes les procédures d'installation à haute altitude CAN/CGA 2.17 à une pression normale. Pour les installations à élévations en haut de 4,500 pieds, appeler le bureau de Navien.

This appliance must be installed in accordance with local codes, or in the absence of local codes, the National Fuel Gas Code, ANSI Z223.1/NFPA 54 or the CSA B149.1, Natural Gas and Propane Installation Code. \*Cet appareil doit être installé selon les règlements locaux, ou en l'absence de tels règlements, selon le National Fuel Gas Code, ANSI Z223.1/NFPA 54, ou les, Code d'installation du gaz naturel et du propane, CSA-B149.1.

**FOR YOUR SAFETY \*POUR VOTRE SÉCURITÉ**

**Do not store or use gasoline or other flammable vapors and liquids in the vicinity of this or any other gas appliances.** \*Ne rangez pas et n'utilisez pas d'essence ou d'autres liquides ou vapeurs inflammables près de cet appareil ou de tout autre appareil électroménager.

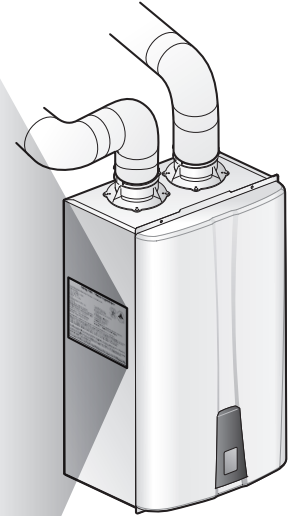

### WARNING

- Be sure the gas type and electricity voltage match the rating plate. Using a different gas type will cause abnormal combustion and water heater malfunction.
- Using abnormally high or low AC voltage may cause abnormal operation, and may reduce the life expectancy of this product.

## 3. Installing the Water Heater

### 3.1 Choosing an Installation Location

When choosing an installation location, you must ensure that the location provides adequate clearance for the water heater, adequate venting and drainage options, and sufficient access to gas, water, and electrical supplies. Carefully consider the following factors when choosing an installation location:

#### About Water Quality

Proper maintenance of the water heater is required to ensure that your water meets EPA quality standards. The following table shows the maximum contaminant levels allowed, based on the EPA National Secondary Drinking Water Regulations (40 CFR Part 143.3). If you suspect that your water is contaminated in any way, discontinue use of the water heater and contact an authorized technician or licensed professional.

| Contaminant                  | Maximum Allowable Level     |
|------------------------------|-----------------------------|
| Total Hardness               | 200 mg/l (12 grains/gallon) |
| Aluminum                     | 0.05 to 0.2 mg/l            |
| Chloride                     | 250 mg/l                    |
| Copper                       | 1.0 mg/l                    |
| Iron                         | 0.3 mg/l                    |
| Manganese                    | 0.05 mg/l                   |
| pH                           | 6.5-8.5                     |
| Sulfate                      | 205 mg/l                    |
| Total Dissolved Solids (TDS) | 500 mg/l                    |
| Zinc                         | 205 mg/l                    |

#### Access to utilities

- Water – the installation location should be near where the domestic water supply enters the building.
- Gas – the installation location should be near where the gas supply enters the building.
- Electricity – the installation location should be near where the electrical supply enters the building.

#### Adequate drainage

The water heater produces a significant amount of condensate during operation. The water heater should be located near a suitable drain and where damage from a possible leak will be minimal. Installing the water heater in a location without a drain will void the warranty and Navien will not be responsible for water damages that occur as a result. For more information about condensate drainage, refer to “3.5 Connecting the Condensate Drain” on page 25.

The water heater should be located in an area where leakage of the unit or connections will not result in damage to the area adjacent to the appliance or to lower floors of the structure. When such locations cannot be avoided, it is recommended that a suitable drain pan, adequately drained, be installed under the water heater. The pan must not restrict combustion air flow.

#### Adequate venting and ventilation

Select a location that requires minimal venting. Consider venting restrictions caused by windows, doors, air intakes, gas meters, foliage, and other buildings. For more information about venting, refer to “3.6 Venting the Water Heater” on page 26.

To ensure adequate venting and ventilation, follow these guidelines:

- Maintain proper clearances from any openings in the building.
- Install the water heater with a minimum clearance of 12 inches (300mm) above an exterior grade or as required by local codes.
- Maintain a minimum clearance of 4 feet (1.2 meters) from heating and cooling vents.
- Do not enclose the vent termination.
- Install the exhaust vent in an area that is free from obstructions and does not allow the exhaust to accumulate.
- Do not install the water heater where moisture from the exhaust may discolor or damage walls.
- Do not install the water heater in bathrooms, bedrooms, or any other occupied rooms that are normally kept closed or that are not adequately ventilated.

#### Proximity to fixtures and appliances

Install the water heater near fixtures that deliver or use hot water, such as bathroom, kitchen, and laundry room faucets. Select a location that minimizes the water piping required between major fixtures. If the distances are long or if the water heater requires “instant” hot water, we recommend running a recirculation line back to the water heater from the furthest fixture. Insulate as much of the hot water supply and recirculation lines as possible. For more information about the water supply, refer to “3.4 Connecting the Water Supply” on page 19.

### Adequate installation clearances

Install the water heater in an area that allows for service and maintenance access to utility connections, piping, filters, and traps. Based on the installation location, ensure the following clearances are maintained:

| Clearance from: | Indoor Installation       | Outdoor Installation      |
|-----------------|---------------------------|---------------------------|
| Top             | 9 inches (229mm) minimum  | 36 inches (900mm) minimum |
| Back            | 0.5 inches (20mm) minimum | 0.5 inches (20mm) minimum |
| Front           | 4 inches (100mm) minimum  | 24 inches (600mm) minimum |
| Sides           | 3 inches (76mm) minimum   | 3 inches (76mm) minimum   |
| Bottom          | 12 inches (300mm) minimum | 12 inches (300mm) minimum |

### Clean, debris and chemical-free combustion air

- Do not install the water heater in areas where dust and debris may accumulate or where hair sprays, spray detergents, chlorine, or similar chemicals are used.
- Do not install the water heater in areas where gasoline or other flammables are used or stored.
- Ensure that combustible materials are stored away from the water heater and that hanging laundry or similar items do not obstruct access to the water heater or its venting.
- In commercial locations, do not install the water heater in areas with greasy fumes or heavy amounts of steam or take measures to prevent fumes and steam from entering the water heater.

### High Elevation Installations

This water heater may be installed at elevations up to 10,100 ft (3,078 m) for use with Natural Gas and 4,500 ft (1,370 m) for use with Propane. Refer to "3.8.2 Setting the Front Panel DIP Switches" on page 34 for the appropriate altitude setting.

## 3.2 Mounting the Water Heater to the Wall

Navien water heaters come with an upper mounting bracket that is pre-drilled at 16 inches on center for easy installation on standard wall studs. If the strength of the wall is insufficient or if the framing is non-standard or uneven, reinforce the area before installing the water heater. Avoid installation on common walls as the unit will make some operational noises while it is running.

To mount the water heater to the wall:

1. Affix the bracket securely to the wall and ensure that it is level and that it can support the weight of the water heater.
2. Align the grooves on the back of the water heater with the tongues on the mounting bracket and hang the water heater on the bracket.

When mounted with the mounting bracket, the water heater will have a 5/8" (16mm) clearance from the back of the wall.

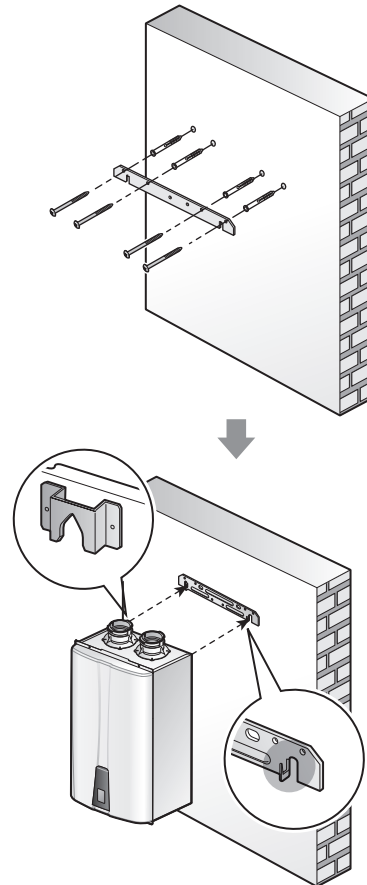

### ! CAUTION

Do not mount the water heater to dry wall that has not been reinforced.

### 3.3 Connecting the Gas Supply

#### WARNING

- Before connecting the gas supply, determine the gas type and pressure for the water heater by referring to the rating plate. Use only the same gas type indicated on the rating plate. Using a different gas type will result in abnormal combustion and malfunction of the water heater. Gas supplies should be connected by a licensed professional only.
- The appliance and its gas connection must be leak tested before placing the appliance in operation.
- This water heater cannot be converted from natural gas to propane or vice versa without a Navien gas conversion kit. Do not attempt a field conversion of this water heater without a Navien gas conversion kit. Doing so will result in dangerous operating conditions and will void the warranty.

Navien recommends connecting the water heater as the first water heater downstream of the gas meter, to ensure a sufficient gas supply.

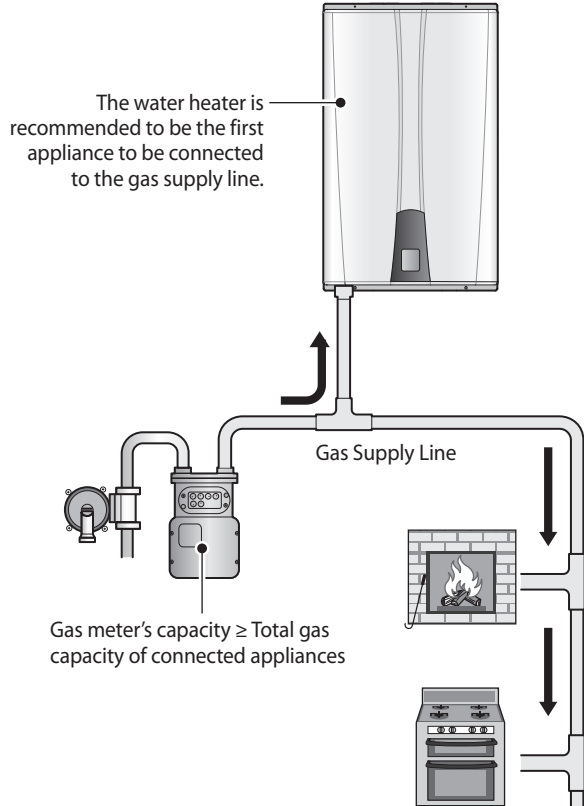

To connect the gas supply:

1. Determine the gas type and pressure for the water heater by referring to the rating plate.
2. Perform a pressure test on the main gas supply line.
3. Purge the gas line of any debris.
4. Determine the proper size and type for the gas line. Refer to the tables that follow.
5. Install full port valves on the gas supply line and water heater.
6. Connect the gas supply line.
7. Test the supply line, all connection points, and the water heater for gas leaks.

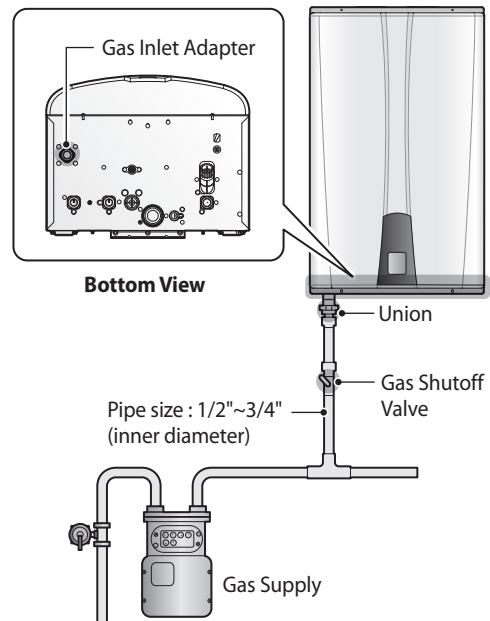

**Note**

- Tighten the water heater connection valves with care to avoid damage.
- The gas connection fitting on all water heaters is 3/4".
- 1/2" rigid pipe can be used; refer to the sizing tables on the preceding pages for limitations. Avoid using 1/2" corrugated connectors or tubing as noise may occur.



**Corrugated Connector**

- When using flexible gas lines, ensure that the pipe's inner diameter and connector is sufficient to supply the required BTUs. Also, ensure that the flexible line has no crimps or tight bends in it, as this will restrict gas flow.
- When using rigid pipe, Navien recommends the installation of a union on the gas supply line close to the water heater, to facilitate any future maintenance or service.

**CAUTION**

Prior to using an excess flow valve (EFV) in the gas line, check the manufacturer's minimum and maximum flow capacity rating. An improperly sized EFV will not allow for a full flow of gas to the water heater and may cause improper operation.

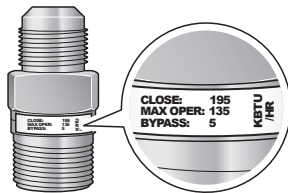

**Excess Flow Valve**

- Typical LP Gas piping examples:

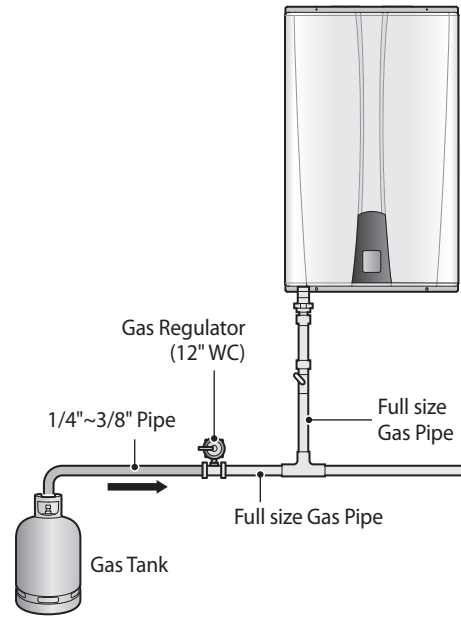

**Single Regulator System**

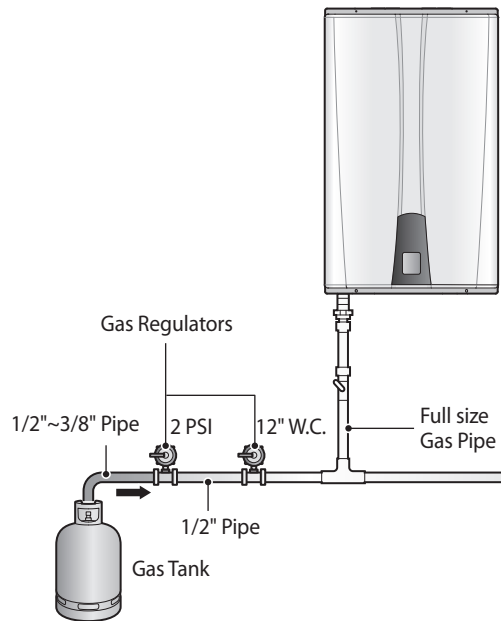

**2-lb. System with Multiple Regulators**

### 3.3.1 Gas Pipe Sizing Tables (Referenced from 2012 National Fuel Gas Code)

These tables are for reference only. Please consult the gas pipe manufacturer for actual pipe capacities.

#### Maximum Natural Gas Delivery Capacity

in Cubic Feet (ft<sup>3</sup>) per Hour (0.60 Specific Gravity; 0.5" WC Pressure Drop). Contact your gas supplier for BTU/ft<sup>3</sup> ratings. Use 1,000 BTU/ft<sup>3</sup> for simplified calculations. This table is recommended for supply pressures less than 6" WC.

| Pipe Size | Length (including fittings) |             |             |              |              |              |              |              |              |               |               |
|-----------|-----------------------------|-------------|-------------|--------------|--------------|--------------|--------------|--------------|--------------|---------------|---------------|
|           | 10'<br>(3m)                 | 20'<br>(6m) | 30'<br>(9m) | 40'<br>(12m) | 50'<br>(15m) | 60'<br>(18m) | 70'<br>(21m) | 80'<br>(24m) | 90'<br>(27m) | 100'<br>(30m) | 125'<br>(38m) |
| 3/4"      | 360                         | 247         | 199         | 170          | 151          | 137          | 126          | 117          | 110          | 104           | 92            |
| 1"        | 678                         | 466         | 374         | 320          | 284          | 257          | 237          | 220          | 207          | 195           | 173           |
| 1 1/4"    | 1,390                       | 957         | 768         | 657          | 583          | 528          | 486          | 452          | 424          | 400           | 355           |
| 1 1/2"    | 2,090                       | 1,430       | 1,150       | 985          | 873          | 791          | 728          | 677          | 635          | 600           | 532           |
| 2"        | 4,020                       | 2,760       | 2,220       | 1,900        | 1,680        | 1,520        | 1,400        | 1,300        | 1,220        | 1,160         | 1,020         |
| 2 1/2"    | 6,400                       | 4,400       | 3,530       | 3,020        | 2,680        | 2,430        | 2,230        | 2,080        | 1,950        | 1,840         | 1,630         |
| 3"        | 11,300                      | 7,780       | 6,250       | 5,350        | 4,740        | 4,290        | 3,950        | 3,670        | 3,450        | 3,260         | 2,890         |
| 4"        | 23,100                      | 15,900      | 12,700      | 10,900       | 9,660        | 8,760        | 8,050        | 7,490        | 7,030        | 6,640         | 5,890         |

in Cubic Feet (ft<sup>3</sup>) per Hour (0.60 Specific Gravity; 3.0" WC Pressure Drop). Contact your gas supplier for BTU/ft<sup>3</sup> ratings. Use 1,000 BTU/ft<sup>3</sup> for simplified calculations. This table is recommended for supply pressures of 6" WC or greater.

| Pipe Size | Length (including fittings) |             |             |              |              |              |              |              |              |               |               |
|-----------|-----------------------------|-------------|-------------|--------------|--------------|--------------|--------------|--------------|--------------|---------------|---------------|
|           | 10'<br>(3m)                 | 20'<br>(6m) | 30'<br>(9m) | 40'<br>(12m) | 50'<br>(15m) | 60'<br>(18m) | 70'<br>(21m) | 80'<br>(24m) | 90'<br>(27m) | 100'<br>(30m) | 125'<br>(38m) |
| 1/2"      | 454                         | 312         | 250         | 214          | 190          | 172          | 158          | 147          | 138          | 131           | 116           |
| 3/4"      | 949                         | 652         | 524         | 448          | 397          | 360          | 331          | 308          | 289          | 273           | 242           |
| 1"        | 1,787                       | 1,228       | 986         | 844          | 748          | 678          | 624          | 580          | 544          | 514           | 456           |
| 1 1/4"    | 3,669                       | 2,522       | 2,025       | 1,733        | 1,536        | 1,392        | 1,280        | 1,191        | 1,118        | 1,056         | 936           |
| 1 1/2"    | 5,497                       | 3,778       | 3,034       | 2,597        | 2,302        | 2,085        | 1,919        | 1,785        | 1,675        | 1,582         | 1,402         |
| 2"        | 10,588                      | 7,277       | 5,844       | 5,001        | 4,433        | 4,016        | 3,695        | 3,437        | 3,225        | 3,046         | 2,700         |
| 2 1/2"    | 16,875                      | 11,598      | 9,314       | 7,971        | 7,065        | 6,401        | 5,889        | 5,479        | 5,140        | 4,856         | 4,303         |
| 3"        | 29,832                      | 20,503      | 16,465      | 14,092       | 12,489       | 11,316       | 10,411       | 9,685        | 9,087        | 8,584         | 7,608         |
| 4"        | 43,678                      | 30,020      | 24,107      | 20,632       | 18,286       | 16,569       | 15,243       | 14,181       | 13,305       | 12,568        | 11,139        |

### Maximum Liquefied Propane Delivery Capacity

in Thousands of BTU/H (0.5" WC Pressure Drop)

| Pipe Size | Length (including fittings) |             |             |              |              |              |              |               |               |               |               |               |               |
|-----------|-----------------------------|-------------|-------------|--------------|--------------|--------------|--------------|---------------|---------------|---------------|---------------|---------------|---------------|
|           | 10'<br>(3m)                 | 20'<br>(6m) | 30'<br>(9m) | 40'<br>(12m) | 50'<br>(15m) | 60'<br>(18m) | 80'<br>(24m) | 100'<br>(30m) | 125'<br>(38m) | 150'<br>(45m) | 175'<br>(53m) | 200'<br>(60m) | 250'<br>(76m) |
| 1/2"      | 291                         | 200         | 160         | 137          | 122          | 110          | 101          | 94            | 89            | 84            | 74            | 67            | 62            |
| 3/4"      | 608                         | 418         | 336         | 287          | 255          | 231          | 212          | 197           | 185           | 175           | 155           | 140           | 129           |
| 1"        | 1,150                       | 787         | 632         | 541          | 480          | 434          | 400          | 372           | 349           | 330           | 292           | 265           | 243           |
| 1 1/4"    | 2,350                       | 1,620       | 1,300       | 1,110        | 985          | 892          | 821          | 763           | 716           | 677           | 600           | 543           | 500           |
| 1 1/2"    | 3,520                       | 2,420       | 1,940       | 1,660        | 1,480        | 1,340        | 1,230        | 1,140         | 1,070         | 1,010         | 899           | 814           | 749           |
| 2"        | 6,790                       | 4,660       | 3,750       | 3,210        | 2,840        | 2,570        | 2,370        | 2,200         | 2,070         | 1,950         | 1,730         | 1,570         | 1,440         |

### 3.3.2 Measuring the Inlet Gas Pressure

**WARNING**

The water heater cannot function properly without sufficient inlet gas pressure. Measuring the inlet gas pressure should be performed by a licensed professional only.

- The inlet gas pressure must be maintained between 3.5" and 10.5" WC for natural gas and between 8.0" and 13" WC for liquefied propane.
- The appliance and its individual shutoff valve must be disconnected from the gas supply piping system during any pressure testing of that system at test pressures in excess of 1/2 psi (3.5 kPa). The appliance must be isolated from the gas supply piping system by closing its individual manual shutoff valve during any pressure testing of the gas supply piping system at test pressures equal to or less than 1/2 psi (3.5 kPa).

To measure the inlet gas pressure:

1. Shut off the manual gas valve on the gas supply line.

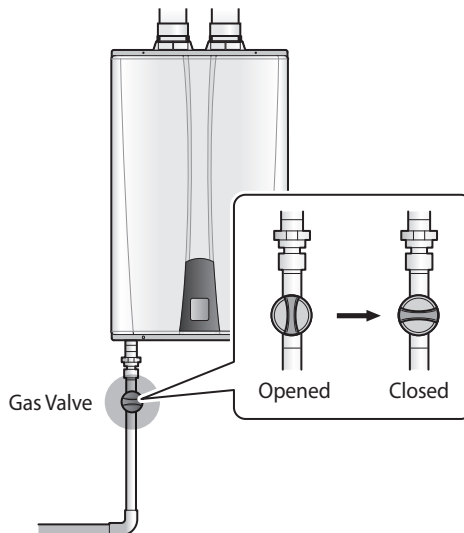

2. Open a hot water faucet. The water heater should turn on and the gas in the gas supply line will be purged.
3. Leave the faucet on until the water heater shuts down due to a lack of gas supply, and then turn off the hot water faucet.
4. Remove the water heater front cover by loosening the 4 Phillips head screws securing it to the case.

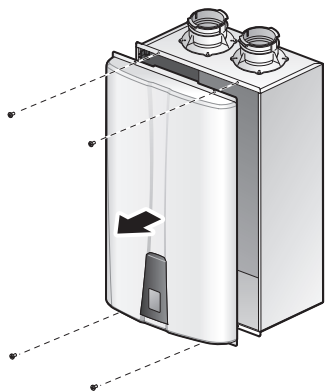

5. Loosen the screw indicated in the figure below and connect a manometer to the pressure port. Reset the manometer to zero before use.

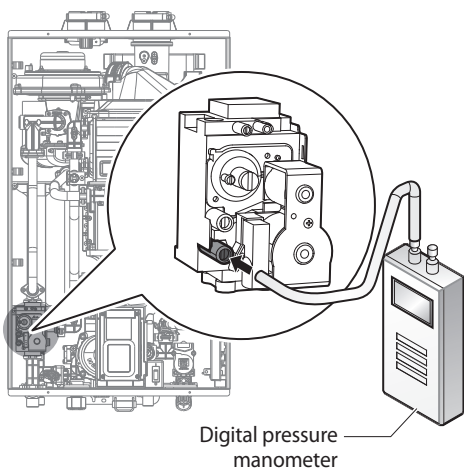

6. Re-open the manual gas valve and check for leaks.
7. Open multiple fixtures that have high flow rates, such as bathtub and shower faucets, to ramp the water heater up to its maximum firing rate.

8. When the water heater reaches its maximum firing rate, check the inlet gas pressure reading on the manometer. The gas pressure must fall within the ranges specified on page 18.

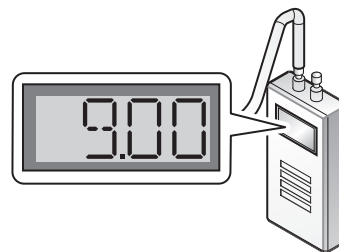

### 3.4 Connecting the Water Supply

The water fittings on the water heater are 3/4". If the installation site only has 1/2" plumbing throughout, it is not necessary to upsize the water lines to 3/4", if you are installing a single water heater. When installing multiple water heaters, the number of water heaters and pipe sizing required will depend on the total hot water demand. For information about pipe sizing for multiple water heaters, refer to "4.1.1 Piping Sizes and Considerations" on page 36.

When connecting the water supply, follow these guidelines:

- Do not remove the factory installed recirculation inlet cap unless a return line is connected to this fitting. Water leakage will occur if this cap is loose or missing ("A" model only).
- Use only pipes, fittings, valves, and other components, such as solder, that are approved for use in potable water systems.
- Tighten the water heater connection valves with care to avoid damage.
- We recommend using unions and manual shut-off valves on the cold water inlet, DHW outlet, and recirculation water inlet.
- Strive to make the hot water piping system as short as possible, to deliver hot water to the fixtures more quickly.
- To conserve water and energy, insulate all water piping—especially the hot and recirculation water lines. Never cover the drain or pressure relief valve. If the water heater is installed in a closed water supply system, such as one having a backflow preventer in the cold water supply line, means shall be provided to control thermal expansion. Contact the water supplier or local plumbing inspector for information about how to control this situation.
- After installing the water heater, clean the inlet water filter that is located inside the cold water inlet, and then test the water heater for proper flow and inspect for leaks. Instruct the water heater owner that the filter must be cleaned periodically to maintain proper water flow.

- The following is a typical water piping example for NPE-180A/ 210A/ 240A models.

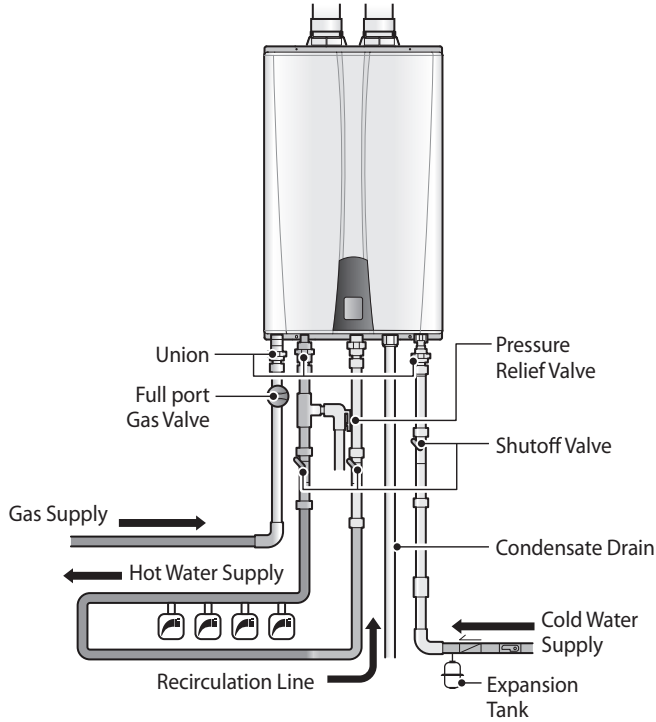

[NPE-180A/ 210A/ 240A]

- NPE-180S/210S/240S

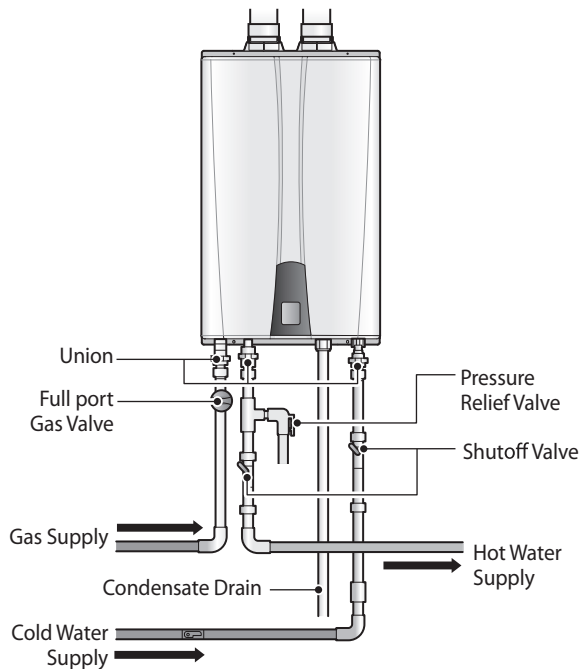

[NPE-180S/ 210S/ 240S]

### 3.4.1 Using the Water Heater for Combination Water Heating and Space Heating

When using the water heater for both water (potable) heating and space heating, follow these guidelines:

- Ensure that all piping and components connected the water heater are suitable for potable water applications.
- Do not introduce toxic chemicals, such as boiler treatments, into the potable water.
- On Combi applications, circulators suitable for DHW applications must be used.
- Do not connect the water heater to any heating systems or components that have been previously used with non-potable water heaters.
- If the system requires varying temperatures for water—for example, hotter water for space heating than for other uses—install a mixing valve to temper the water and reduce the potential for scalding.
- Do not use the water heater for space heating only.
- Make sure circulator flow rate through the Water Heater does not exceed 4 GPM.

### 3.4.2 Selecting a Recirculation Mode ("A" model only)

On all "A" model Navien water heaters, you can choose from two pre-heating modes: internal recirculation mode or external recirculation mode. To select a recirculation mode, you must set the DIP switches on the front panel, and set the position of the 2-way valve inside the water heater. By default, the DIP switches are set to OFF.

When you use a recirculation mode, there will be some minor efficiency loss, as a result of the water heater maintaining a steady temperature within the circulation loop. Although in many cases, higher gas usage will be made up for by lower water usage.

The recirculation feature of the "A" models has three performance advantages:

- Elimination of any minimum flow rate requirement.
- Elimination of any hot/cold/hot stacking—the "cold water sandwich" effect.
- Quicker hot water delivery to fixtures, which results in less water wasted.

**Note**

When using external recirculation mode with the built-in pump, observe the following maximum recirculation pipe lengths including fittings (3/4" pipe is recommended):

- 1/2" Copper Pipe- 100' (30m) of equivalent length
  - 3/4" Copper Pipe- 500' (150m) of equivalent length
- Lengths in excess of these limits will require an external recirculation pump.

### Internal Recirculation Mode

To use the internal recirculation mode:

1. Connect the water supply.
2. Set the 2-way valve inside the water heater to "INT."

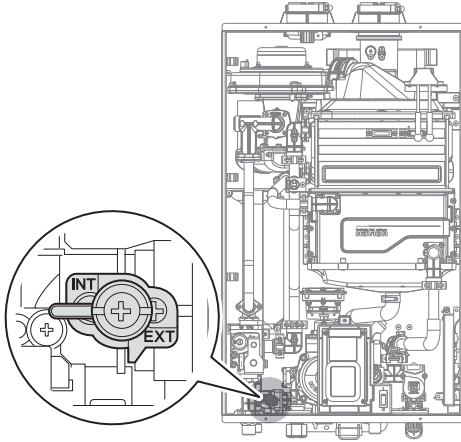

3. Set the front panel DIP switches at the far left (set of ten) to: 1—ON; 2—OFF.

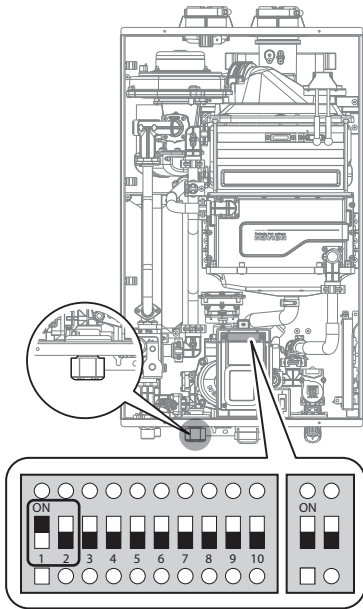

### CAUTION

Do not remove recirculation cap. (Internal Recirculation Mode)

The following diagram shows the internal recirculation flow for pre-heating:

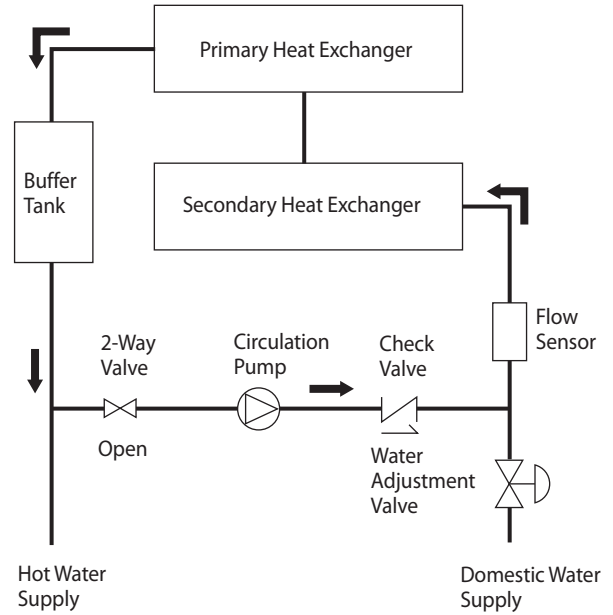

Internal Recirculation Mode

### External Recirculation Mode

To use the external recirculation mode:

1. Connect the water supply to support recirculation. Refer to the "[NPE-180A/ 210A/ 240A]" diagram on page 20.
2. Set the 2-way valve inside the water heater to "EXT."

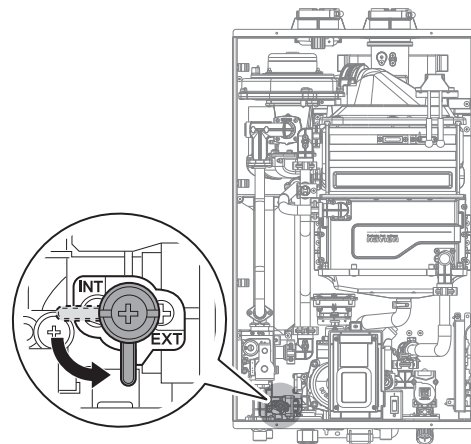

- Set the front panel DIP switches at the far left (set of ten) to: 1—OFF; 2—ON.

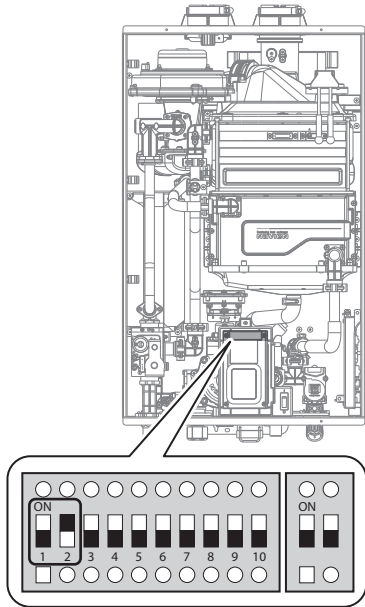

The following diagram shows the external recirculation flow for pre-heating:

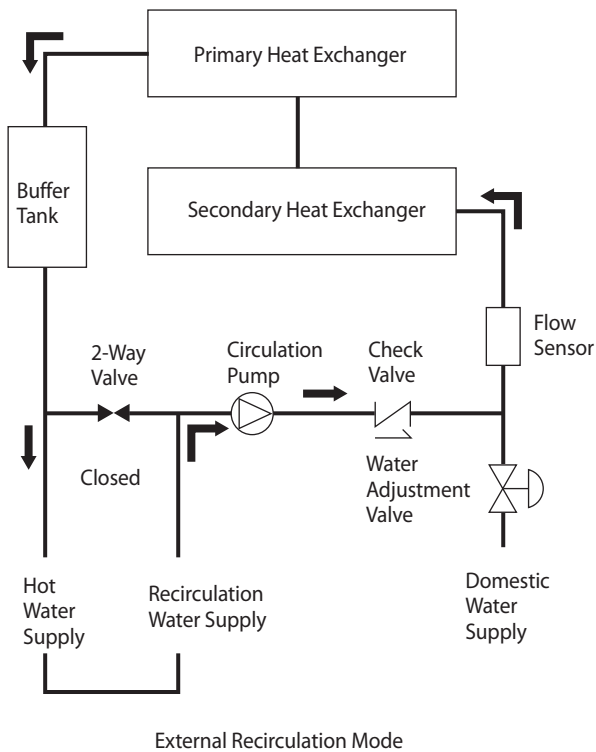

### 3.4.3 External Pump Wire Connection

An external pump may be connected to the water heater for recirculation applications. When selecting a circulator, it shall be sized to maintain a flow of 2-4 GPM through the water heater. Follow the instructions below when connecting the pump wire accessory to the PCB.

#### **! WARNING**

Failure to follow the instructions below may result in property damage, personal injury or death. To avoid the danger of electric shock, make sure that the water heater is turned off before connecting the wire to the PCB.

<Specifications>

- Maximum Power Consumption: 150W, 1.5A
  - Length: 6 ft (183 cm)
- ※ When using a pump with larger power requirements than the listed specification above, a relay should be used to ensure proper operation.
- Remove the water heater front cover by loosening the 4 Phillips head screws securing it to the case.

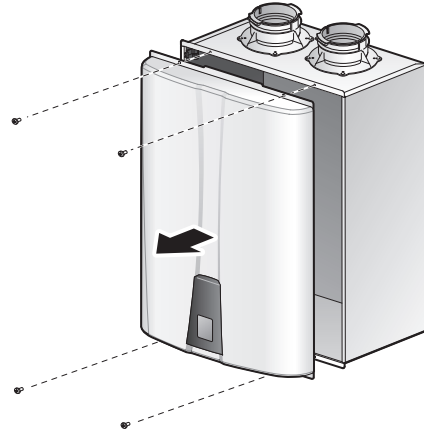

- Locate the power switch on the right side of the front panel and switch the system off.

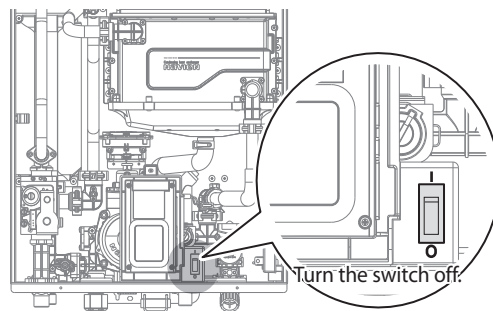

- Remove the 2 screws holding the PCB box in place and remove the PCB box from the system.

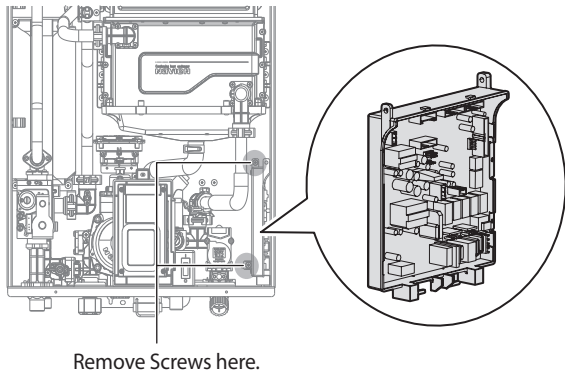

- Connect the external pump wiring connector to the connector socket on the PCB (TB1).

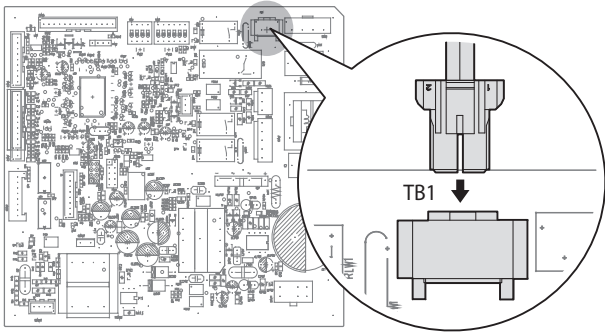

- Put the PCB box back in its original place and secure it using the 2 mounting screws.
- Remove the plastic insulation from the external pump wire with a wire stripper before connecting it to the pump.

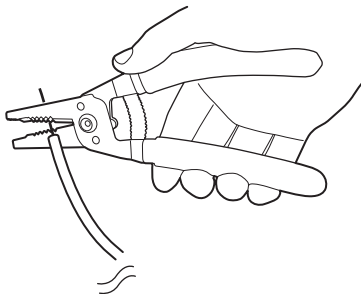

- Connect the External Pump Wire to the proper wires from the pump junction box.

**WARNING**

To avoid the danger of electric shock, turn on the water heater **ONLY** after connecting the wire to the external pump.

- Locate the 10-switch DIP (SW1) on the front panel and turn on the proper switches based on the desired recirculation setting (see Recirculation Dipswitch Settings below).

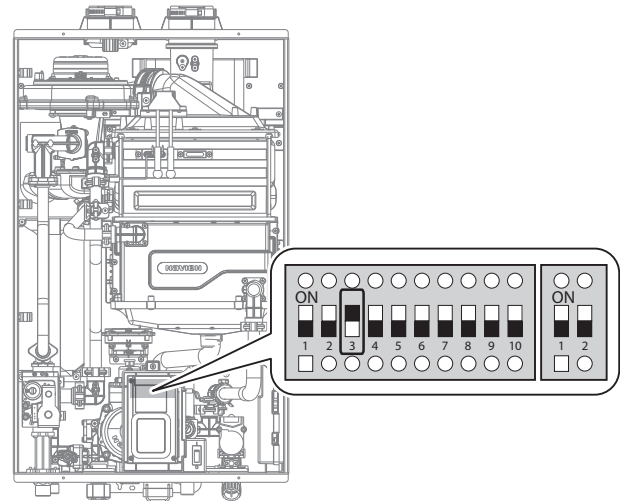

- Turn on the switch beside the front panel.
- Put the water heater cover back on and secure it with the 4 screws.

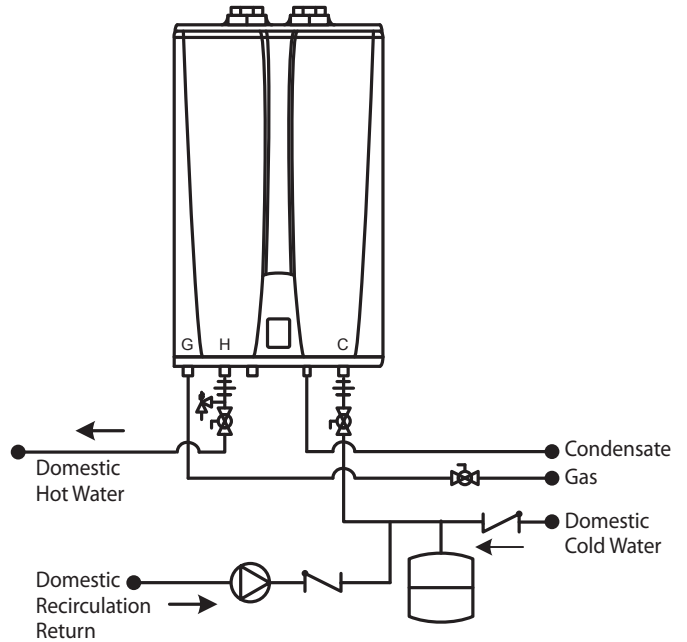

**Recirculation Using External Pump Only**

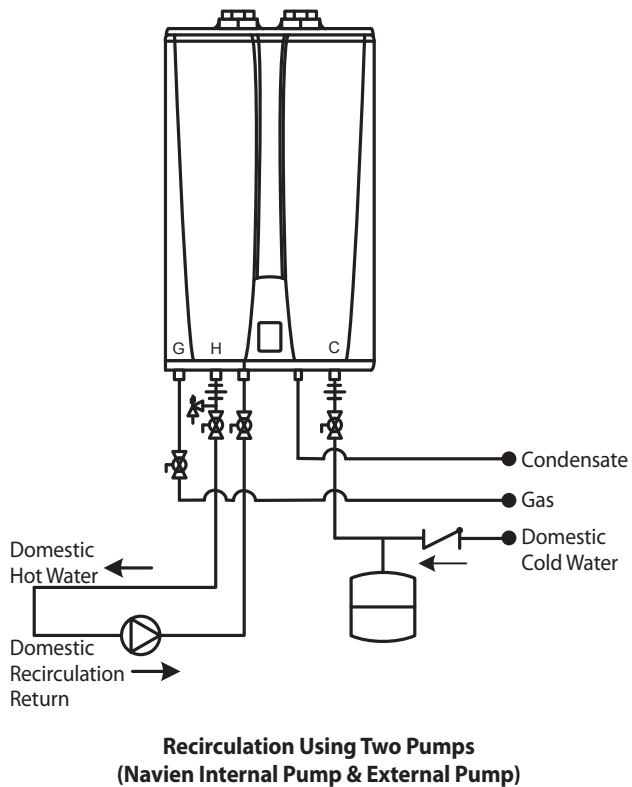

To complete the installation of the water heater, you must install an approved 3/4", maximum 150 PSI pressure relief valve on the hot water outlet. The water heater has a built-in high temperature shut off switch, so install a "pressure only" relief valve. This valve is not supplied, but is required. The following examples are approved for use with the water heater:

- Wilkins P-1000A (Zurn Industries)
- Conbraco 17-402-04
- Watts Industries 3L(M7)
- Cash Acme FWL-2, 3/4"

The pressure relief valve should be placed as close to the water heater as possible. No other valve should be placed between the pressure relief valve and the water heater.

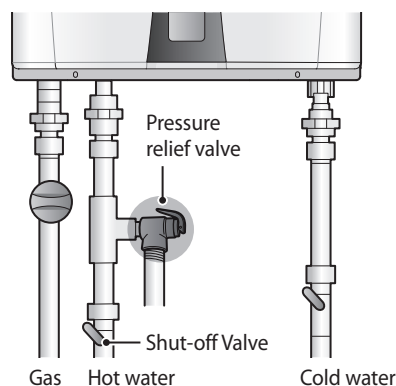

### 3.4.4 Connecting a Pressure Relief Valve

#### **WARNING**

Improper installation of the pressure relief valve may result in property damage, personal injury, or death. Follow all instructions and guidelines when installing the pressure relief valve. The valve should be installed only by a licensed professional.

When installing the valve, follow these guidelines:

- Ensure that the discharge capacity of the pressure relief valve is equal to or greater than the maximum pressure rating of the water heater.
- Ensure that the maximum BTU/H rating on the pressure relief valve is equal to or greater than the maximum input BTU/H rating of the water heater.
- Direct the discharge piping of the pressure relief valve so that hot water will not splash on anyone or any nearby equipment.
- Attach the discharge line to the pressure relief valve and run the end of the line to within 6-12" (150-300mm) of the floor.
- Ensure that the discharge line will allow free and complete drainage without restriction. Do not install a reducing coupling or other restriction on the discharge line.
- If the relief valve discharges periodically, this may be due to thermal expansion in a closed water supply system. Contact the water supplier or local plumbing inspector on how to correct this situation. Do not plug the relief valve.

### 3.5 Connecting the Condensate Drain

The Navien Condensing Water Heater creates condensation when it operates. This condensation has an acidic pH of 3-5. Follow all local codes and regulations when disposing of condensate from the water heater. We recommend draining the condensate into a laundry tub, as the alkali in laundry detergent will neutralize the acid in the condensate. However, other suitable waste drain locations may be used according to local codes.

#### CAUTION

- Do not cap or plug the integrated condensate line. If prevented from draining, condensate can damage the water heater.
- The condensate line must have a negative slope to drain properly.

Before connecting the condensate drain, choose one of the following disposal options:

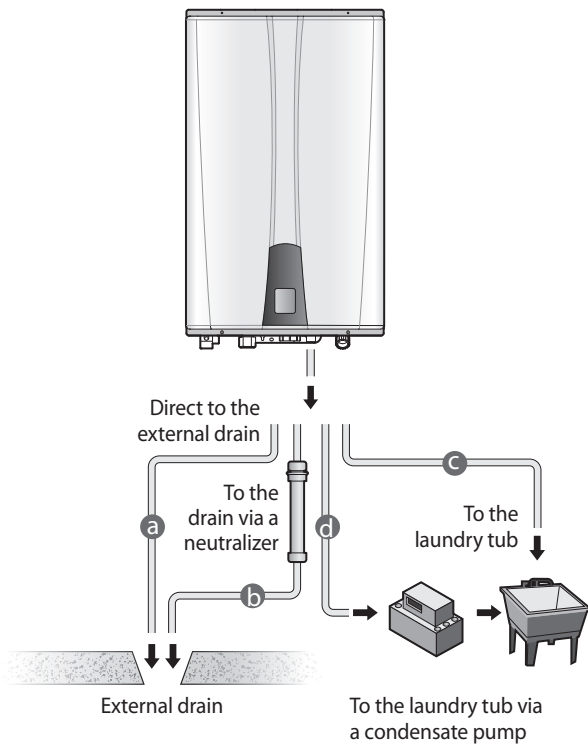

- From the water heater directly into an external drain.
- From the water heater, through a neutralizing agent, and then into an external drain.

#### Note

If you choose this option, the neutralizing agent must be replaced periodically. Depletion of the neutralizing agent will vary, based on the usage rate of the water heater. During the first year of operation, the neutralizer should be checked every few months for depletion and replaced as needed.

- From the water heater into a laundry tub.

#### Note

The bottom of the water heater must be higher than the top of the laundry tub to use this option. The condensate line must have a negative slope to drain properly.

- From the water heater into a condensate pump, and then into a laundry tub.

#### Note

A pump can be used when there is a long distance between the water heater and the laundry tub or when the bottom of the water heater is lower than the top of the laundry tub.

To connect the condensate drain:

- Connect a drain line to the 1/2" fitting at the bottom of the water heater.

Use only corrosion-resistant material for the drain line, such as PVC or CPVC. Do not reduce the size of this fitting or the drain line to less than 1/2".

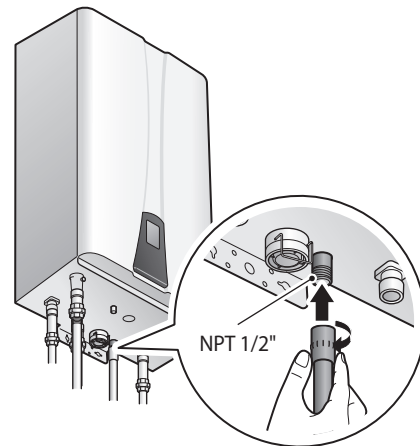

- Place the free end of the drain line into an appropriate drain.
- If you are using a condensate pump, ensure that the pump allows for up to 2 GPH of drainage for each water heater in the system.

If you are not using a condensate pump, ensure that the drain line is pitched downward at a minimum slope of 1/4" per foot.

## 3.6 Venting the Water Heater



### WARNING

Improper venting of the water heater can result in excessive levels of carbon monoxide, which can lead to severe personal injury or death. **This water heater must be vented in accordance with the “Venting of Equipment” section of the latest edition of the ANSI Z223.1/NFPA 54 Natural Fuel Gas Code in the USA and/or the “Venting systems and air supply for water heaters” section of the latest version of the CAN/CGA B149.1 Natural Gas and Propane Installation Code in Canada, as well as all applicable local building codes and regulations.** Follow all instructions and guidelines when venting the water heater. Venting should be performed only by a licensed professional.

The water heater must be properly vented to ensure a constant supply of clean intake air and to ensure that exhaust air is properly removed from living areas. When venting the water heater, follow these guidelines:

- Do not install the water heater in areas with contaminated air (containing a high level of dust, sawdust, sand, flour, aerosols, or any other such airborne contaminants), as contaminants can cause operational problems. The warranty does not cover damage caused by contaminants in the installation area. If you must install the water heater in an area with contaminated air, use direct venting to supply air from outside the building. We recommend regular filter cleaning and maintenance in these areas.
  - For best results, keep the venting system as short and straight as possible.
  - Locate the water heater as close as possible to the vent termination.
  - Do not connect the water heater vent to a vent for any other gas water heater or vent stack.
  - For horizontal runs, slope the horizontal section upward toward the vent termination at a rate of 1/4" per foot (2% slope).
  - Create an airtight seal at each joint in the exhaust and intake air pipes from the water heater collar to the vent termination.
  - To avoid moisture and frost build-up and to maintain clearances to openings on adjacent homes, 45° elbows, 90° elbows, or tees may be attached to the end of the termination vent pipe to direct the exhaust plumes away from buildings, as long as the total allowable vent lengths, maximum number of elbows, and distances to air intake restrictions are observed.
- Do not store hazardous or flammable substances near the vent termination.
  - If this water heater will be installed in areas where snow is known to accumulate, protect the vent termination from blockage.
  - Ensure that the vent termination is at least 12" (305mm) above ground, or as required by local codes.
  - Support the vent pipe with hangers at regular intervals or as required by local codes.
  - Exhaust and intake air pipes must be supported at least every 4 feet (1.2m).
  - The vent for this appliance shall not terminate over public walkways; or near soffit vents or crawl space vents or where condensate or vapor could create a nuisance or hazard or cause property damage; or where condensate or vapor could cause damage or could be detrimental to the operation of regulators, relief valves, or other equipment.

### 3.6.1 Selecting a Vent Type

All water heaters are prepared at the factory to be direct vent (sealed combustion) water heaters that draw all of their required combustion air directly from outside the building. Navien recommends direct air vent installations whenever possible to avoid back drafting cold air through the water heater. If you cannot use a direct vent, ensure that an ample supply of make-up air is available in the installation location.

Navien also recommends installing a new vent system with this appliance. If reusing an existing vent system, thoroughly inspect it for punctures, cracks, or blockages prior to connecting it to the water heater.

#### Direct Venting

The water heater uses 2" or 3" diameter exhaust and 2" or 3" diameter intake air ducts. To ensure the draw of air directly from and exhaust of air directly to the outside of the building, create an airtight seal from the water heater collar to the vent termination.

Intake materials can be made of ABS, PVC, CPVC, PP, galvanized steel, corrugated aluminum or any other such materials. If you use a corrugated material, ensure that there is not inadvertent crimping of, or damage to, the intake air pipe.

When using direct venting, maintain the following venting clearances, as required by **ANSI Z21.10.3 and the National Fuel Gas Code, ANSI Z223.1/NFPA 54, and CAN/CGA B149.1 Natural Gas and Propane Installation Code:**

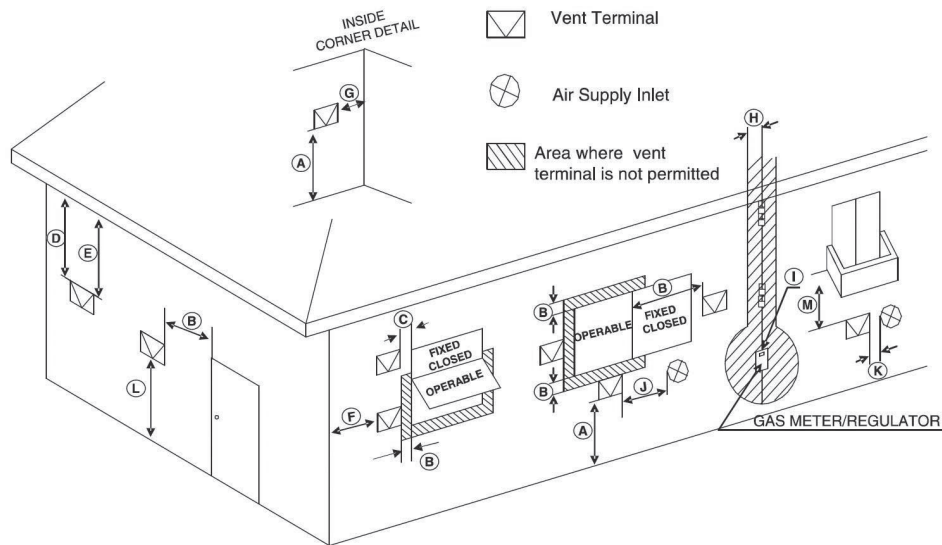

| Ref | Description  | Canadian Direct Vent Installations <sup>1</sup>                       | US Direct Vent Installations <sup>2</sup>             |
|-----|--|---|---|
| A   | Clearance above grade, veranda, porch, deck, or balcony  | 12 in (30 cm)   | 12 in (30 cm)   |
| B   | Clearance to window or door that may be opened   | 36 in (91 cm)   | 12 in (30 cm)   |
| C   | Clearance to permanently closed window   | *   | *   |
| D   | Vertical clearance to ventilated soffit located above the terminal within a horizontal distance of 2 feet (61 cm) from the center line of the terminal | *   | *   |
| E   | Clearance to unventilated soffit   | *   | *   |
| F   | Clearance to outside corner  | *   | *   |
| G   | Clearance to inside corner   | *   | *   |
| H   | Clearance to each side of center line extended above meter/regulator assembly  | 3 ft (91 cm) within a height 15 ft above the meter/regulator assembly | *   |
| I   | Clearance to service regulator vent outlet   | 3 ft (91 cm)  | *   |
| J   | Clearance to nonmechanical air supply inlet to building or the combustion air inlet to any other appliance   | 36 in (91 cm)   | 12 in (30 cm)   |
| K   | Clearance to a mechanical air supply inlet   | 6 ft (1.83 m)   | 3 ft (91 cm) above if within 10 ft (3 m) horizontally |
| L   | Clearance above paved sidewalk or paved driveway located on public property  | 7 ft (2.13 m) †   | *   |
| M   | Clearance under veranda, porch deck, or balcony  | 12 in (30 cm) ‡   | *   |

<sup>1</sup> In accordance with the current CSA B149.1 Natural Gas and Propane Installation Code

<sup>2</sup> In accordance with the current ANSI Z223.1 / NFPA 54 National Fuel Gas Code

† A vent shall not terminate directly above a sidewalk or paved driveway that is located between two single family dwellings and serves both dwellings.

‡ Permitted only if veranda, porch, deck, or balcony is fully open on a minimum of two sides beneath the floor.

\* Clearance in accordance with local installation codes and the requirements of the gas supplier.

**Non-Direct Venting (Single Pipe)**

If, at any time, the installation location could experience negative pressure, there is a possibility of back drafting cold air through the water heater’s heat exchanger. This situation could lead to the freezing of the heat exchanger and malfunction of the water heater.

However, building codes in most jurisdictions disallow negative pressures in residences. In a home with a well-balanced air supply, the heat exchanger should not be in danger of freezing. Because the cause of back drafting is not considered a manufacturing problem, any freezing damage which occurs from back drafting will not be covered by the Navien warranty. If there is any question about the possibility of back drafting in the installation location, use a direct venting system for the water heater.

When installed in a manufactured home (mobile home), all combustion air must be supplied from the outdoors as described on page 26.

When using non-direct venting, maintain non-direct vent clearances shown on page 29 as required by **ANSI Z21.10.3 and the National Fuel Gas Code, ANSI Z223.1/NFPA 54, and CAN/CSA B149.1 Natural Gas And Propane Installation Code.**

To use non-direct venting for the water heater:

1. Insert the termination end cap into the intake air duct. Do not glue the end cap, to allow for easy removal and cleaning of the cap.

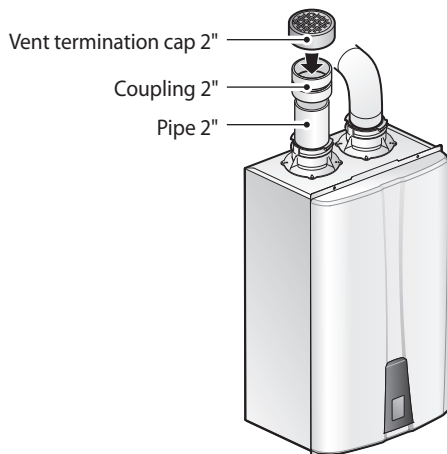

2. Provide two openings to allow for circulation of combustion air as specified by ANSI Z223.1/NFPA 54 or CAN/CGA B-149.1:

|   | NPE-180A<br>NPE-180S                               | NPE-210A<br>NPE-210S                               | NPE-240A<br>NPE-240S                               |
|---|--|--|--|
| Maximum Input (BTU/H)   | 150,000  | 180,000  | 199,900  |
| Outdoor make up air is provided, a minimum free area of 1 in <sup>2</sup> , per 4,000 BTU/H | 40 in <sup>2</sup><br>10" (W) x 4" (H) or 3" round | 45 in <sup>2</sup><br>10" (W) x 5" (H) or 3" round | 50 in <sup>2</sup><br>10" (W) x 5" (H) or 3" round |
| Indoor make up air is provided, a minimum free area of 1 in <sup>2</sup> per 1,000 BTU/H    | 150 in <sup>2</sup><br>12 1/4" (W) x 12 1/4" (H)   | 180 in <sup>2</sup><br>13 1/4" (W) x 13 1/4" (H)   | 199 in <sup>2</sup><br>14 1/4" (W) x 14 1/4" (H)   |

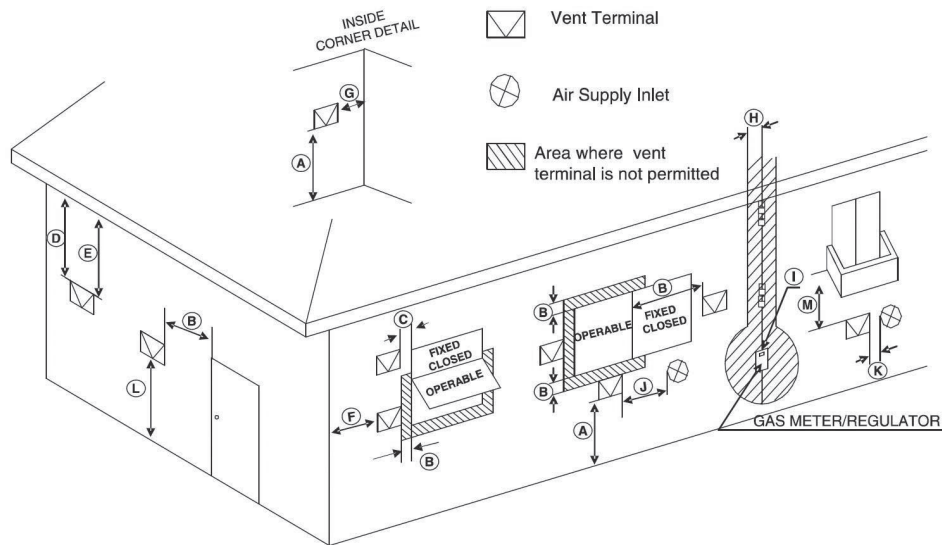

| Ref | Description  | Canadian Non-Direct Vent Installations <sup>1</sup>                             | US Non-Direct Vent Installations <sup>2</sup>                           |
|-----|--|---|---|
| A   | Clearance above grade, veranda, porch, deck, or balcony  | 12 in (30 cm)   | 12 in (30 cm)   |
| B   | Clearance to window or door that may be opened   | 36 in (91 cm)   | 48 in (120 cm) below or to side of opening; 12 in (30 cm) above opening |
| C   | Clearance to permanently closed window   | *   | *   |
| D   | Vertical clearance to ventilated soffit located above the terminal within a horizontal distance of 2 feet (61 cm) from the center line of the terminal | *   | *   |
| E   | Clearance to unventilated soffit   | *   | *   |
| F   | Clearance to outside corner  | *   | *   |
| G   | Clearance to inside corner   | *   | *   |
| H   | Clearance to each side of center line extended above meter/regulator assembly  | 36 in (91 cm) within a height 15 ft (4.57 m) above the meter/regulator assembly | *   |
| I   | Clearance to service regulator vent outlet   | 36 in (91 cm)   | *   |
| J   | Clearance to nonmechanical air supply inlet to building or the combustion air inlet to any other appliance   | 36 in (91 cm)   | 48 in (120 cm) below or to side of opening; 12 in (30 cm) above opening |
| K   | Clearance to a mechanical air supply inlet   | 6 ft (1.83 m)   | 36 in (91 cm) above if within 10 ft (3 m) horizontally                  |
| L   | Clearance above paved sidewalk or paved driveway located on public property  | 7 ft (2.13 m) †   | *   |
| M   | Clearance under veranda, porch deck, or balcony  | 12 in (30 cm) ‡   | *   |

<sup>1</sup> In accordance with the current CSA B149.1 Natural Gas and Propane Installation Code

<sup>2</sup> In accordance with the current ANSI Z223.1 / NFPA 54 National Fuel Gas Code

† A vent shall not terminate directly above a sidewalk or paved driveway that is located between two single family dwellings and serves both dwellings.

‡ Permitted only if veranda, porch, deck, or balcony is fully open on a minimum of two sides beneath the floor.

\* Clearance in accordance with local installation codes and the requirements of the gas supplier.

### 3.6.2 Selecting Vent Pipe Materials

Venting requirements differ in the US and Canada. Consult the following chart or the most recent edition of ANSI Z223.1/NFPA 54 or CAN/CGA B149.1, as well as all applicable local codes and regulations when selecting vent pipe materials. Do not use cellular core based pipe materials for the exhaust vent.

| Locale  | Recommended Vent Materials  |
|---------|---|
| USA     | <ul style="list-style-type: none"> <li>PVC Schedule 40 (Solid Core)</li> <li>CPVC Schedule 40 or 80 (Solid Core)</li> <li>Approved Polypropylene</li> </ul>   |
| Canada* | <ul style="list-style-type: none"> <li>Type BH Special Gas Vent Class IIA (PVC)</li> <li>Type BH Special Gas Vent Class IIB (CPVC)</li> <li>Type BH Special Gas Vent Class IIC (Polypropylene)</li> </ul> |

\* For installation in Canada, field-supplied plastic vent piping must comply with CAN/CGA B149.1 (latest edition) and be certified to the Standard For Type BH Gas Venting Systems, ULC-S636. Components of this listed system must not be interchanged with other vent systems or unlisted pipes or fittings. All plastic components and specified primers and glues of the certified vent system must be from a single system manufacturer and must not be intermixed with another system manufacturer's parts. The supplied vent connector and vent termination are certified as part of the water heater.

#### CAUTION

- This water heater has a built-in control to limit the exhaust temperature to 149°F (65°C). As a result, the Navien water heater can be vented with Schedule 40 PVC. If the incoming (or recirculation return) water temperature does not exceed 150°F (66°C), the exhaust temperature will not exceed 149°F (65°C).
- However, if you set the water heater at a temperature above 150°F (66°C) and you are also incorporating either an external recirculation loop or a combination heating system, the exhaust temperature can exceed 149°F (65°C). In that case, you must use Schedule 40 or 80 CPVC or Approved Polypropylene in the USA or Type BH Special Gas Vent Class IIB (CPCV) or Class IC (Polypropylene) that conforms to ULC-S636 in Canada.

### 3.6.3 Measuring Vent Length

The maximum vent length when using 2" exhaust ducts is 60'. The maximum vent length when using 3" vent ducts is 150'. The intake duct length can be of equal length to the exhaust duct length. Both maximum lengths are reduced by the number of elbows used, as shown in the following table:

| Vent Size | Maximum Length | Maximum # of Elbows | Equivalent Lengths   |
|-----------|----------------|---------------------|--|
| 2"        | 60' (18m)      | 6                   | Reduce the maximum vent length accordingly for each elbow used: <ul style="list-style-type: none"> <li>Each 90° elbow equates to 8 linear feet (2.4m) of vent</li> <li>Each 45° elbow equates to 4 linear feet (1.2m) of vent</li> </ul> |
| 3"        | 150' (45m)     | 8                   | Reduce the maximum vent length accordingly for each elbow used: <ul style="list-style-type: none"> <li>Each 90° elbow equates to 5 linear feet (1.5m) of vent</li> <li>Each 45° elbow equates to 3 linear feet (0.9m) of vent</li> </ul> |

#### Note

- The Maximum Length does not include any elbows.
- If using a concentric termination as shown on pages 31-32, count this as 5 linear feet (1.5m) of vent.
- The maximum vent lengths at high altitudes are the same as shown in the table above.

### 3.6.4 Terminating the Vent

Before installing the water heater, determine what type of vent termination is appropriate for the installation location and situation. The subsections that follow describe some typical venting configurations, but do not include all possible options.

#### Indoor Water Heater Installation Venting Examples

The following are some possible indoor venting options:

- 2" or 3" Two-pipe Sidewall Venting

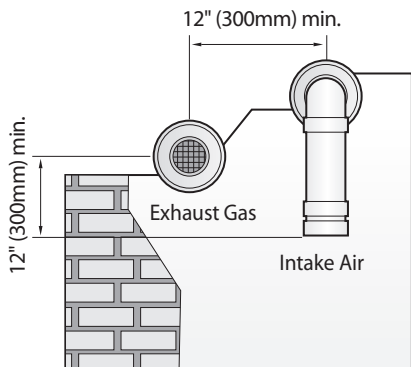
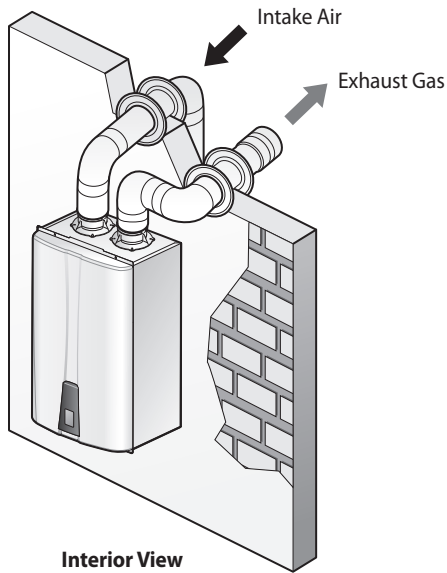

- Non-concentric Sidewall Venting – Air is drawn from a different location at a minimum of 12" (300mm) from the exhaust termination. Try to minimize the length of the intake air pipe with this venting.

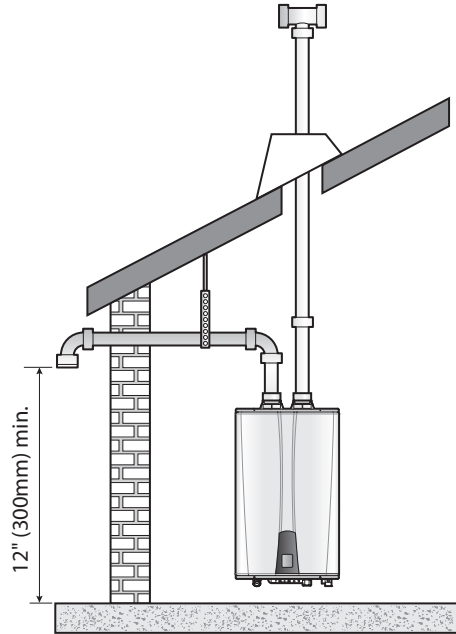

- Concentric Sidewall Venting

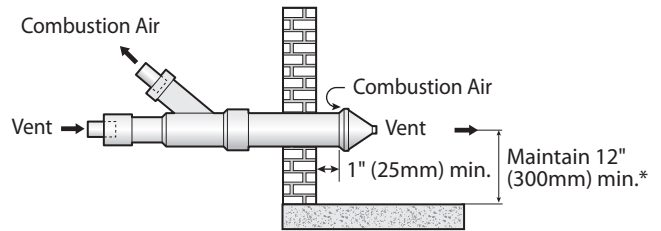

\* Clearance above highest anticipated snow level or grade.

- 2" or 3" Two-pipe Vertical Venting – Intake and exhaust pipes do not have to terminate in the same area.

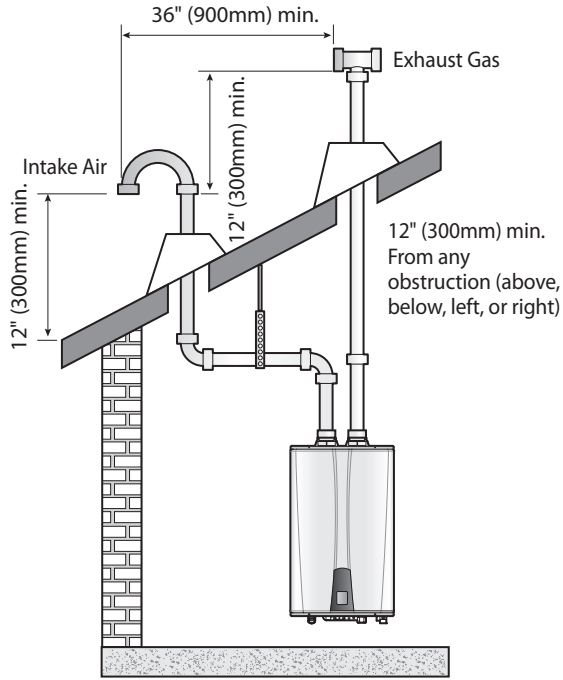

- Concentric Roof Venting

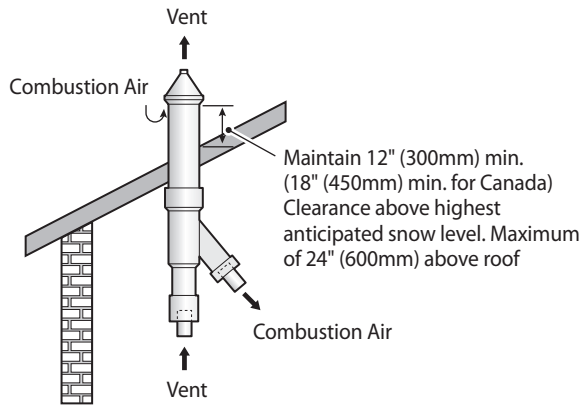

### Outdoor Installation

Outdoor installation should only be considered in mild climates. Freezing temperatures or contaminated air can damage the water heater. When installing the water heater outdoors, maintain clearances from building openings, as described in the "Non-Direct Venting (Single Pipe)" section on page 28. Outdoor installation areas should be in an open, unroofed area and should allow for the following minimum clearances from the water heater:

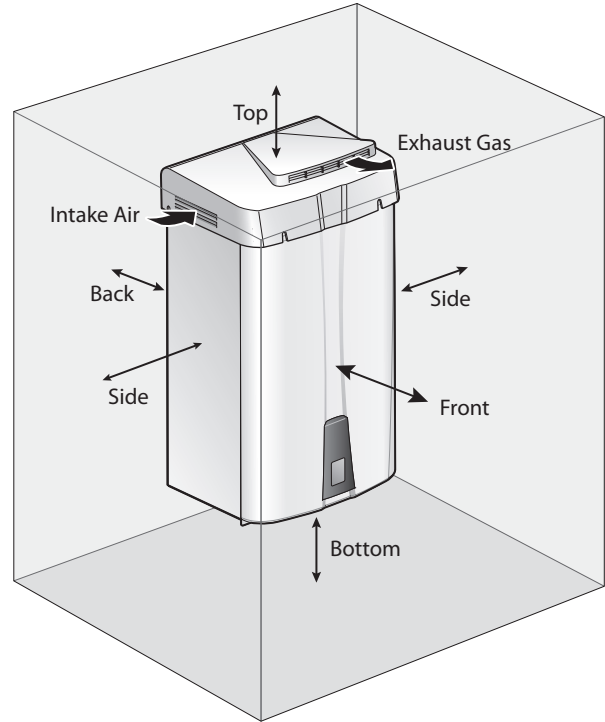

|        |      |
|--------|------|
| Bottom | 12"  |
| Back   | 0.5" |
| Sides  | 3"   |
| Front  | 24"  |
| Top    | 36"  |

When installing a water heater outdoors, follow these guidelines:

- The Navien Outdoor Vent Kit must be used to ensure proper operation of the water heater.
- Ensure that there is plenty of clearance around the air intake and that it is adequately protected to prevent any debris, liquids, or flammable gases from entering the air intake.
- If the water heater is installed under an eave, maintain a clearance of 3 feet or more from the eave to the top of the water heater vent terminals.

### 3.7 Connecting the Power Supply

#### **WARNING**

Improperly connecting the power supply can result in electrical shock and electrocution. Follow all applicable electrical codes of the local authority having jurisdiction. In the absence of such requirements, follow the latest edition of **the National Electrical Code (NFPA 70) in the USA or the latest edition of CSA C22.1 Canadian Electrical Code Part 1 in Canada**. Connecting the power supply should be performed only by a licensed professional.

When connecting the power supply, follow these guidelines:

- Do not connect the electric supply until all plumbing and gas piping is complete and the water heater has been filled with water.
- Do not connect the water heater to a 220-240V AC power supply. Doing so will damage the water heater and void the warranty.
- All water heaters come with a factory-installed, 3-pronged (grounded) plug. The water heater can be plugged into any grounded electrical outlet nearby, as it requires only 2-4 Amps. It is not necessary to run a dedicated electrical line to the water heater.
- If local codes require the water heater to be wired directly, remove and discard the factory-installed plug. Install a power switch between the breaker and the water heater to facilitate end-user maintenance and servicing. Connect the water heater to a 110-120V AC at 60 Hz with a maximum of 2A (4A if an external pump is connected) rating electrical supply.
- The water heater must be electrically grounded. If using the power plug, ensure that the electrical outlet you connect the water heater to is properly grounded. If wiring the water heater directly to a power supply, do not attach the ground wire to either the gas or the water piping as plastic pipe or dielectric unions may prevent proper grounding.
- We recommend using a surge protector to protect the water heater from power surges.
- If there is a power failure in cold weather areas, the freeze prevention system in the water heater will not operate and may result in freezing of the heat exchanger. In cold weather areas where power failures are common, you must completely drain the water heater to prevent damage if the power will be off for any extended period of time. A battery back-up (available at most computer retailers) may be used to supply hot water during periods of power outages. Damage caused by freezing is not covered under warranty.

### 3.8 Setting the DIP Switches

The water heater has two DIP switch locations: on the main circuit board (PCB) and on the front panel. Each location has two sets of DIP switches that control the functionality of the water heater. Set the DIP switches appropriately, based on the installation environment.

#### 3.8.1 Circuit Board DIP Switches

The two sets of DIP switches on the circuit board configure the water heater's model settings. These configurations are set at the factory and should not be changed.

#### 3.8.2 Setting the Front Panel DIP Switches

The two sets of DIP switches on the front panel configure the water heater's pump & recirculation, display, well pump, storage tank & solar system, lime alarm, high altitude, Cascade Venting and Gas Type settings. Some of these configurations are set at the factory and should not be changed. The following tables describe the functions of the DIP switches and their settings:

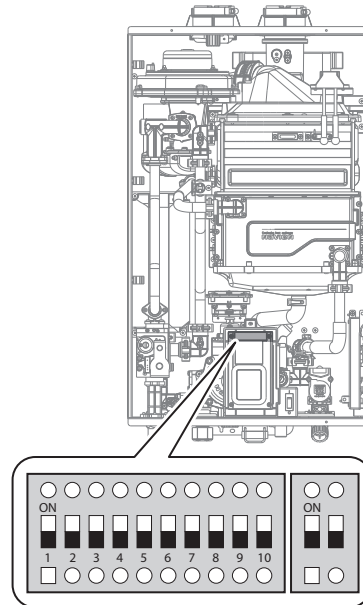

• 10-switch Panel:

| Switch | Function   | Setting                                 |                     | Remark  |
|--------|--|---|---------------------|---|
| 1-3    | Recirculation Mode-<br>Internal Navien<br>Pump ("A" model<br>only) | No Recirculation                        | 1-OFF; 2-OFF; 3-OFF | <p><b>*Intelligent Preheating:</b><br/>Learns the user's hot water usage patterns and starts preheating prior to an anticipated draw.</p> <ul style="list-style-type: none"> <li>• Preheating starts when remote controller is not connected.</li> <li>• When remote controller is connected, preheating starts and operates based on the timer.</li> <li>• Set the timer on the remote controller to use hot water at the time of your choice.</li> <li>• Intelligent preheating does not function in Cascade Mode (Preheating OFF).</li> <li>• Freeze protection is still available with preheating OFF.</li> </ul> <p><b>**External Pump:</b><br/>These settings are to be used when an external pump is wired to the water heater.</p> <p><b>***Lime Alarm:</b><br/>Displays a "760" error when the set time period has been reached to indicate a flush or service is necessary.</p> <p><b>****High Altitude</b><br/>Above 2,000 ft (610 m), the water heater will de-rate by 4% for each 1,000 ft (305 m) of altitude gain.</p> |
|        |  | Internal Recirculation                  | 1-ON; 2-OFF; 3-OFF  |   |
|        |  | External Recirculation                  | 1-OFF; 2-ON; 3-OFF  |   |
|        |  | Intelligent Preheating*                 | 1-ON; 2-ON; 3-OFF   |   |
|        | Recirculation Mode-<br>External Pump<br>Connected**                | External Pump Only                      | 1-OFF; 2-OFF; 3-ON  |   |
|        |  | Internal Recirculation ("A" model only) | 1-ON; 2-OFF; 3-ON   |   |
|        |  | External Recirculation ("A" model only) | 1-OFF; 2-ON; 3-ON   |   |
|        |  | Intelligent Preheating*                 | 1-ON; 2-ON; 3-ON    |   |
| 4      | Display Temperature<br>Unit  | Celsius                                 | 4-ON                |   |
|        |  | Fahrenheit                              | 4-OFF               |   |
| 5      | Well Pump  | Well Pump Operation                     | 5-ON                |   |
|        |  | Do Not Use Well Pump                    | 5-OFF               |   |
| 6      | DHW Storage Tank/<br>Solar System                                  | Storage Tank/Solar System Operation     | 6-ON                |   |
|        |  | Do Not Use Storage Tank/Solar System    | 6-OFF               |   |
| 7 & 8  | Lime Alarm***  | 6 Months Alert                          | 7-ON; 8-OFF         |   |
|        |  | 12 Months Alert                         | 7-OFF; 8-ON         |   |
|        |  | 24 Months Alert                         | 7-ON; 8-ON          |   |
| 9 & 10 | High Altitude ****   | 0 ~ 1,999 ft (0 ~ 609 m)                | 9-OFF, 10-OFF       |   |
|        |  | 2,000 ~ 5,399 ft (610 ~ 1,645 m)        | 9-ON, 10-OFF        |   |
|        |  | 5,400 ~ 7,699 ft (1,646 ~ 2,346 m)      | 9-OFF, 10-ON        |   |
|        |  | 7,700 ~ 10,100 ft (2,347 ~ 3,078 m)     | 9-ON, 10-ON         |   |

**Note**

This water heater may be installed at elevations up to 10,100 ft (3,078 m) for use with Natural Gas and 4,500 ft (1,370 m) for use with Propane. To use the water heater at a specific altitude, the DIP switches should be set as described above.

• 2-switch Panel:

| Switch | Function     | Setting         |       |
|--------|--------------|-----------------|-------|
| 1      | Cascade Vent | Common Vent     | 1-OFF |
|        |              | Individual Vent | 1-ON  |
| 2      | Gas Type     | Natural Gas     | OFF   |
|        |              | Propane Gas     | ON    |

## 4. Installing a Cascading System

When installing a cascading system, carefully consider the design of the system and the features of the installation location. Follow all local codes and regulations, as well as all guidelines for installing the water heater. The following sections describe additional considerations that are specific to installing cascading systems. Read them carefully before designing or installing the system.

### 4.1 Connecting Water Supplies

Several options are available for plumbing a cascading system of water heaters. The options shown here are only examples. The setup you choose will vary based on the installation location, local building codes, and other factors. Follow all applicable regulations when installing a cascading system.

You can connect up to 16 water heaters to meet high-volume hot water demands. Some possible connection options include the following:

- Recirculation via Internal Pumps (“A” model only):

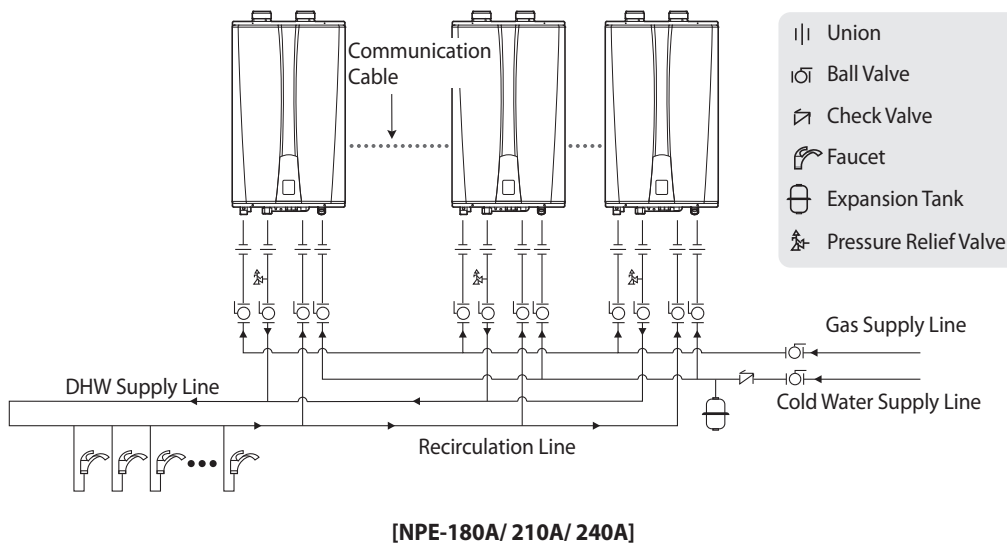

**Note**

The recommended minimum recirculation flow rate for each water heater is 2 GPM. Depending on the number of water heaters and the diameter of the recirculation line, it may not be necessary to connect all water heaters to the recirculation line. If this is the case, set the unconnected water heaters to internal recirculation mode. The master water heater must always be connected to the recirculation line and set to external recirculation mode.

- NPE-S

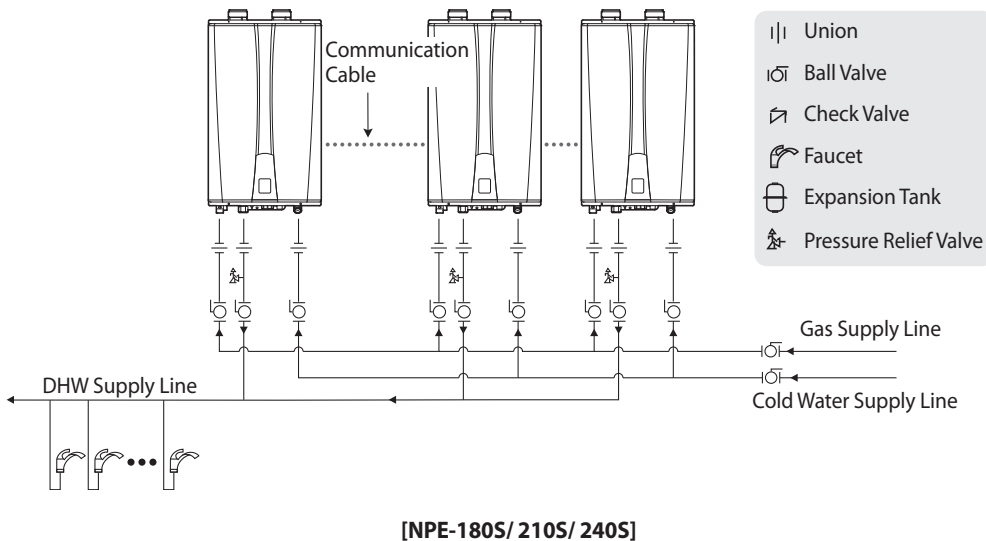

### 4.1.1 Piping Sizes and Considerations

When plumbing a cascading system, consider the following pipe diameters and flow rates. Note that flow rates above 6.6 ft/s may cause pipe erosion. These specifications may vary depending on installation conditions.

| Qty | $\Delta T=54^{\circ}F$<br>Flow rate (GPM) | Water<br>Velocity (ft/s) | Pipe<br>Diameter (mm/in) |        |
|-----|---|--------------------------|--------------------------|--------|
| 1   | 7.19                                      | 4.78                     | 20A                      | 3/4"   |
| 2   | 14.38                                     | 5.61                     | 25A                      | 1"     |
| 3   | 21.57                                     | 5.54                     | 30A                      | 1 1/4" |
| 4   | 28.77                                     | 5.21                     | 40A                      | 1 1/2" |
| 5   | 35.96                                     | 6.53                     | 40A                      | 1 1/2" |
| 6   | 43.15                                     | 4.49                     | 50A                      | 2"     |
| 7   | 50.34                                     | 5.24                     | 50A                      | 2"     |
| 8   | 57.5                                      | 6.00                     | 50A                      | 2"     |
| 9   | 64.72                                     | 4.39                     | 65A                      | 2 1/2" |
| 10  | 71.92                                     | 4.75                     | 65A                      | 2 1/2" |
| 11  | 79.11                                     | 5.34                     | 65A                      | 2 1/2" |
| 12  | 86.30                                     | 5.84                     | 65A                      | 2 1/2" |
| 13  | 93.49                                     | 6.33                     | 65A                      | 2 1/2" |
| 14  | 100.68                                    | 6.79                     | 65A                      | 2 1/2" |
| 15  | 107.87                                    | 5.11                     | 80A                      | 3"     |
| 16  | 115.07                                    | 5.44                     | 80A                      | 3"     |
| 17  | 122.26                                    | 5.81                     | 80A                      | 3"     |
| 18  | 129.45                                    | 6.14                     | 80A                      | 3"     |
| 19  | 136.64                                    | 6.46                     | 80A                      | 3"     |
| 20  | 143.83                                    | 6.83                     | 80A                      | 3"     |
| 21  | 151.02                                    | 4.06                     | 100A                     | 4"     |
| 22  | 158.21                                    | 4.25                     | 100A                     | 4"     |
| 23  | 165.41                                    | 4.45                     | 100A                     | 4"     |
| 24  | 172.60                                    | 4.65                     | 100A                     | 4"     |
| 25  | 179.79                                    | 4.85                     | 100A                     | 4"     |
| 26  | 186.98                                    | 5.05                     | 100A                     | 4"     |
| 27  | 194.17                                    | 5.24                     | 100A                     | 4"     |
| 28  | 201.36                                    | 5.44                     | 100A                     | 4"     |
| 29  | 208.56                                    | 5.61                     | 100A                     | 4"     |
| 30  | 215.75                                    | 5.81                     | 100A                     | 4"     |

**Note** The table above is based on model NPE-240A.

### 4.2 Connecting the Communication Cables

Up to 16 water heaters can be connected with Navien Ready-Link communication cables. Select one of the water heaters in the cascading system as the master water heater, and then connect the other water heaters to it as slaves. Before making any connections, ensure that the power is turned off to all water heaters.

Connect the Ready-Link cables to the J6 ports on the right side of the front panel:

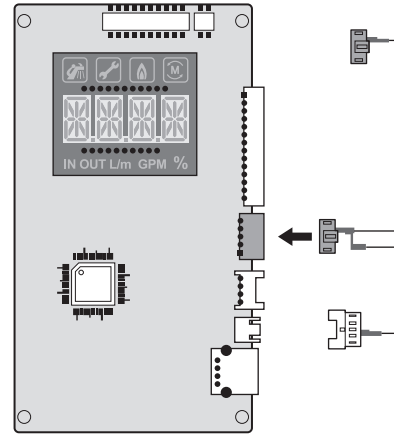

#### 4.2.1 Configuring the Communication Settings

After connecting the Ready-Link communication cables, restore power to the water heater and turn on all water heaters using the Power button.

To configure the communication settings:

1. On the master water heater, press and hold the **Diagnostic** and **Up(+)** buttons for more than 5 seconds. "MA.00" will appear on the display to confirm that this water heater is set as the master.

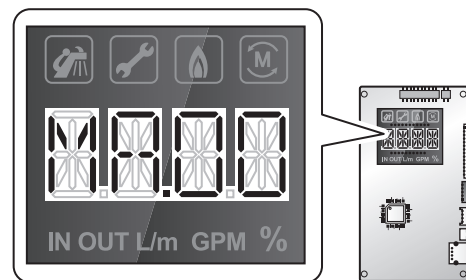

2. On the slave water heater, press and hold the **Diagnostic** and **Down(-)** buttons for more than 2 seconds. "SL.01" will appear on the display to confirm that this water heater is set as a slave.

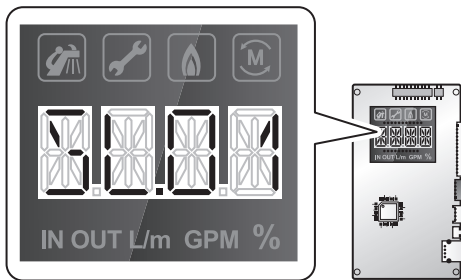

3. Repeat step 2 to configure the rest of the slave water heaters in the system.
4. On the master water heater, press and hold the **Diagnostic** and **Up(+)** buttons for more than 5 seconds. All the display screens on the configured water heaters will return to the temperature display.

**Note**

- To add additional slaves at a later time, repeat step 2.
- To cancel the cascading communication setup, on the master water heater, press and hold the **Diagnostic** and **Reset** buttons for more than 5 seconds. The water heaters will revert to independent operation. Repeat steps 1-4 to reassign the master water heater.

## 5. Appendixes

### 5.1 Gas Conversion

This water heater is configured for Natural Gas from the factory. If conversion to Propane Gas is required, the conversion kit supplied with the water heater must be used.

#### WARNING

This conversion kit shall be installed by a qualified service agency\* in accordance with Navien America's instructions and all applicable codes and requirements of the authority having jurisdiction. The information in these instructions must be followed to minimize the risk of fire or explosion or to prevent property damage, personal injury or death. The qualified service agency is responsible for the proper installation of this kit. The installation is not proper and complete until the operation of the converted appliance is checked as specified in the manufacturer's instructions supplied with the kit.

\* A qualified service agency is any individual, firm, corporation or company which either in person or through a representative is engaged in and is responsible for the connection, utilization, repair or servicing of gas utilization equipment or accessories; who is experienced in such work, familiar with all precautions required, and has complied with all of the requirements of the authority having jurisdiction.

**In Canada:** The conversion shall be carried out in accordance with the requirements of the provincial authorities having jurisdiction and in accordance with the requirements of the CAN-B149.1 and CAN1-B149.2 Installation Code.

#### Tools Required:

- Phillips Screwdriver
- Flathead Screwdriver
- 5/32 " or 4mm Allen Wrench
- Combustion Analyzer or Dual Port Manometer
- Gas Leak Detector

#### Included Items:

- Gas Orifice (refer to below table)

| Water Heater         | NG     |        | LP     |        |
|----------------------|--------|--------|--------|--------|
|                      | 1STAGE | 2STAGE | 1STAGE | 2STAGE |
| NPE-180A<br>NPE-180S | Ø4.80  | Ø5.95  | Ø3.80  | Ø4.60  |
| NPE-210A<br>NPE-210S | Ø6.10  | Ø6.30  | Ø4.50  | Ø4.80  |
| NPE-240A<br>NPE-240S | Ø6.10  | Ø6.30  | Ø4.50  | Ø4.80  |

Table 1. Orifice size

- Gas Pressure and Conversion Kit Number Labels

#### Procedure:

1. Turn off both gas and water supply to the water heater.
2. Using a Phillips hand screwdriver, remove 4 screws (2 from the top and 2 from the bottom) of the front cover assembly to gain access to the internal components. See Figure 1 for illustration of the front cover on the unit.



Figure 1. NPE Series Front cover

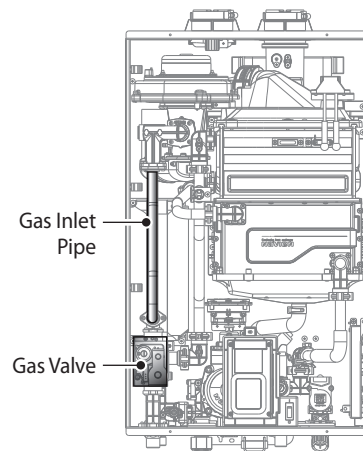

Figure 2. NPE Series Internal Components

3. Once the front cover is removed, place it in a safe location to prevent accidental damage. With the internal components exposed, locate the gas inlet pipe and the Gas Valve near the left side of the unit which are highlighted in Figure 2.
4. Use a Phillips screwdriver to remove the two screws at Location A - the connection below the Gas Valve where it connects to the pipe. See Figure 3 for reference. Once the screws are removed, carefully separate the pipe from the Gas Valve.
5. Once the gas inlet pipe is detached from the Gas Valve, find Location B - the connection above the Gas Valve where it is attached to the Fan Motor Assembly. Carefully remove the four screws by hand using a Phillips screwdriver and pull the Gas Valve away from the Fan Assembly to access the Gas Orifice.

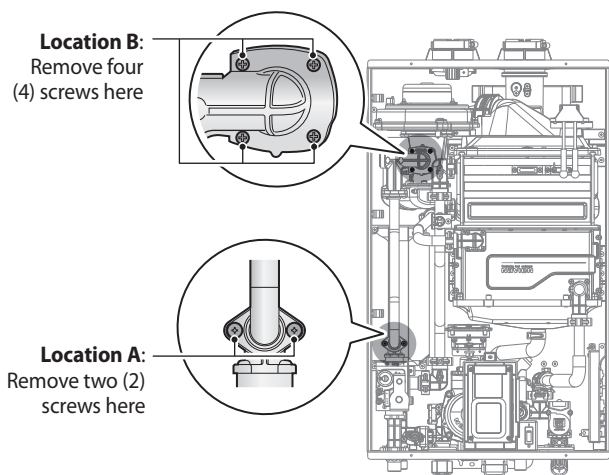

Figure 3. Detaching Gas Valve from Gas Inlet Pipe and Fan Motor Assembly

6. Once the Gas Orifice is exposed, remove the two screws that hold the part in place. Remove the Gas Orifice from its housing and prepare the new Gas Orifice for the LP conversion for installation.

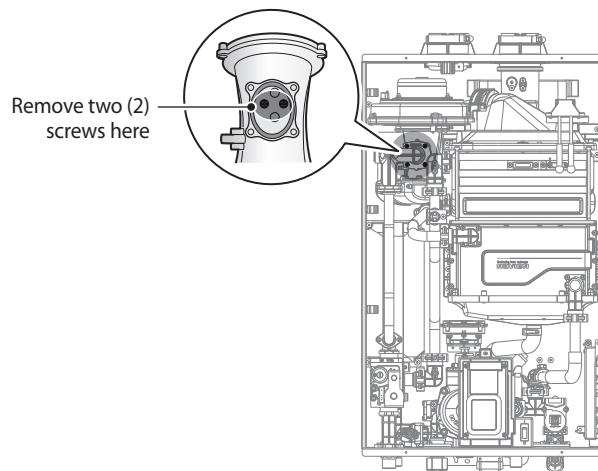

Figure 4. Access to Gas Orifice in Fan Assembly

**! WARNING**

- DO NOT adjust or attempt to measure gas valve outlet pressure. The gas valve is factory-set for the correct outlet pressure. This setting is suitable for natural gas and propane, requiring no field adjustment.
- Attempting to alter or measure the gas valve outlet pressure could result in damage to the valve, causing potential severe personal injury, death or substantial property damage. Navien water heaters are shipped ready to fire natural gas ONLY.

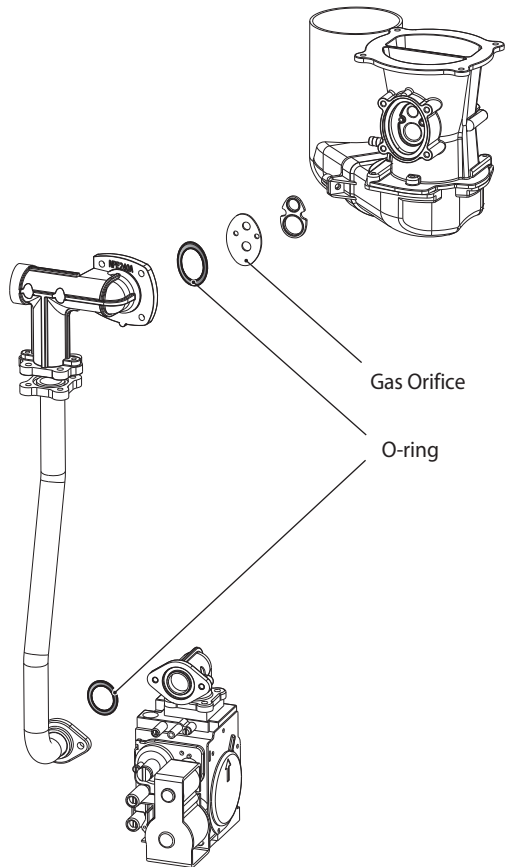

Figure 5. Exploded view of Gas assembly

**! DANGER**

See Figure 5. Inspect the O-ring between the gas valve and gas valve inlet adapter whenever they are disassembled. The O-ring must be in good condition and must be installed. Failure to comply will cause a gas leak, resulting in severe personal injury or death.

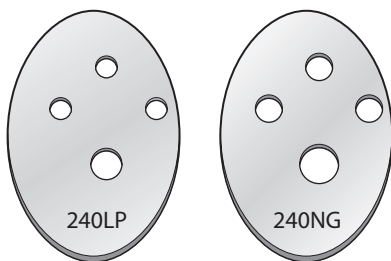

Figure 6. Orifice identification

7. Replace the old Orifice piece with the new part for use with LP gas. Ensure that the Orifice is properly seated inside the port before proceeding to the next step.

8. Replace the gas inlet pipe to its original position and use all screws to secure all connections.

**Note** Do not overtighten as this may damage or crack the components.

**! DANGER**

Inspect the O-ring between the gas valve and gas valve inlet adapter whenever they are disassembled. The O-ring must be in good condition and must be installed. Failure to comply will cause a gas leak, resulting in severe personal injury or death.

9. Set the Front Panel Dip switch according to the gas type.

**! WARNING**

Be sure to turn off the power before changing the DIP switch setting.

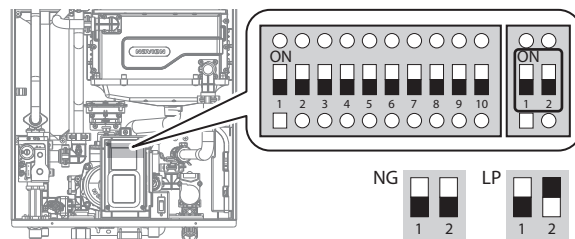

**! DANGER**

- When conversion is required, be sure to set the Front Panel DIP switches according to the supply gas type.
- Failure to properly set the DIP switches could cause carbon monoxide poisoning, resulting in severe personal injury or death.

10. Turn on the gas and water supply to the water heater.

11. Measure and adjust the gas/air ratio.

Option 1. Using Combustion Analyzer (recommended)

- a. Loosen the screw, rotate the plate and remove the gasket to access the emissions monitoring port as shown in Figure 7.
- b. Insert the analyzer into the port (Figure 7).

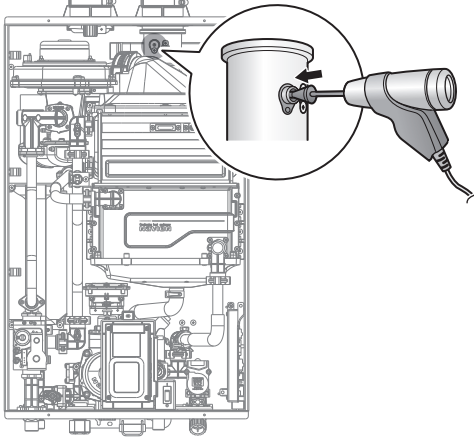

Figure 7

- c. Fully open several hot water fixtures and set the water heater to operate at 1-stage MIN mode (refer to page 43). Measure the CO<sub>2</sub> value at low fire. If the CO<sub>2</sub> value is not within 0.5% of the value listed in Table 2, the gas valve set screw will need to be adjusted. If adjustment is necessary, locate the set screw as shown in Figure 8. Using a 5/32" or 4mm Allen wrench, turn the set screw no more than 1/4 turn clockwise to raise or counterclockwise to lower the CO<sub>2</sub> value.

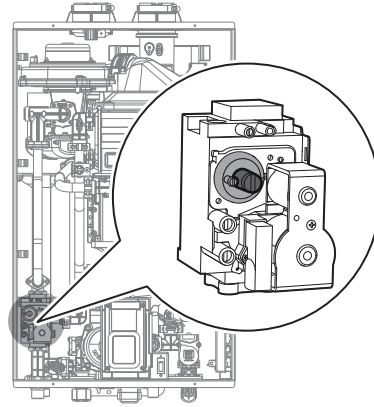

Figure 8. Set Screw Location

| Water Heater | Fuel | High fire        | Low fire         |
|--------------|------|------------------|------------------|
|              |      | %CO <sub>2</sub> | %CO <sub>2</sub> |
| NPE-180A     | NG   | 8.9              | 9.5              |
| NPE-180S     | LP   | 10.2             | 10.8             |
| NPE-210A     | NG   | 8.9              | 9.5              |
| NPE-210S     | LP   | 10.2             | 10.8             |
| NPE-240A     | NG   | 8.9              | 9.5              |
| NPE-240S     | LP   | 10.2             | 10.8             |

Table 2. CO<sub>2</sub> and CO value  
(CO<sub>2</sub> values must be within 0.5% of the values listed.)

**Note** The set screw is located behind the screw-on cover. This must be removed first.

- d. Fully open several hot water fixtures and set the water heater to operate at 2-stage MAX mode (refer to page 43). Measure the CO<sub>2</sub> value at high fire. If the CO<sub>2</sub> values do not match Table 2 at high fire, do not adjust the gas valve. Check for the proper Gas Orifice.

**! DANGER**

Improper gas valve settings can cause severe personal injury, death or substantial property damage.

Option 2. Using Digital Manometer

- a. Open the offset pressure port by loosening the screw two turns as shown in Figure 9.

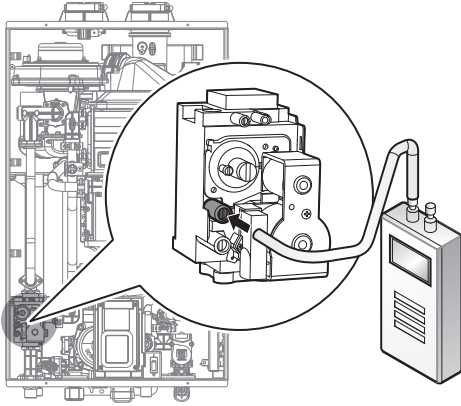

Figure 9

- b. Connect a manometer to the offset pressure port. For dual port manometers, use the positive pressure side.

| Model    | Kit Part No. | Gas Type | Offset       |
|----------|--------------|----------|--------------|
| NPE-180A | NAC-01       | LP       | -0.03"±0.01" |
| NPE-180S | NAC-100      | NG       | -0.04"±0.01" |
| NPE-210A | NAC-02       | LP       | -0.02"±0.01" |
| NPE-210S | NAC-200      | NG       | -0.04"±0.01" |
| NPE-240A | NAC-03       | LP       | -0.02"±0.01" |
| NPE-240S | NAC-300      | NG       | -0.04"±0.01" |

Table 3. Offset value for low fire

- c. Fully open a hot water fixture and set the water heater to operate at 1-stage MIN mode (refer to page 43). Measure the offset value at low fire and compare it to the values in Table 3. If the offset value is out of range, the gas valve set screw will need to be adjusted. If adjustment is necessary, locate the set screw as shown in Figure 10. Using a 5/32" or 4mm Allen wrench, turn the set screw no more than 1/4 turn clockwise to raise or counterclockwise to lower the offset value.

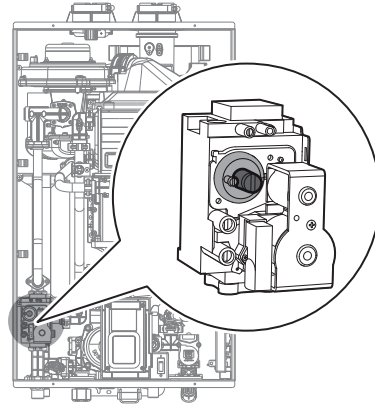

Figure 10

**Note** The set screw is located behind the screw-on cover. This must be removed first.

- d. At high fire, do not check the offset value and never adjust the gas valve.

**! DANGER**

Improper gas valve settings can cause severe personal injury, death or substantial property damage.

12. Once the CO<sub>2</sub> or offset values have been confirmed, apply the included conversion stickers to show that the appliance has been converted to propane gas. Place this labels adjacent to the rating plate as shown in Figure 11.

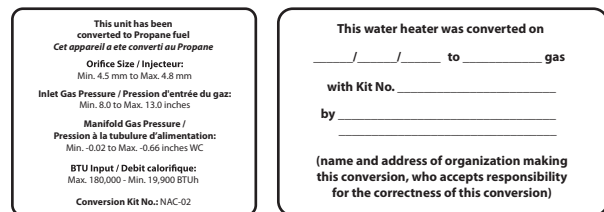

Figure 11. Proper Placement of Gas Conversion Labels

### 5.1.1 Setting the Operation Mode

1. Using the Front Panel, press and hold the Diagnostics Button for over 5 seconds until "1.TST" is displayed.
2. Press the + (Up) button once to change the display to "2.OPR".
3. Press the Information Button once to access the Operation Mode menu.
4. Press the + (Up) button once to set the water heater to operate at 1-stage MIN ("MIN.1").
5. To set the water heater to operate at 2-stage MAX, press the + (Up) button 3 times or until "MAX.2" is displayed.
6. To exit the Operation Mode and return the water heater to normal operation, press the Reset button twice.



## 5.2 Technical Data

### Pressure Drop Curve

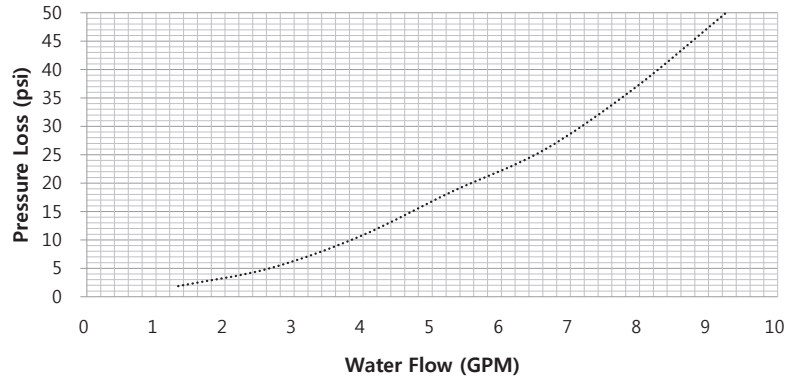

**[NPE-240A/ 240S]**

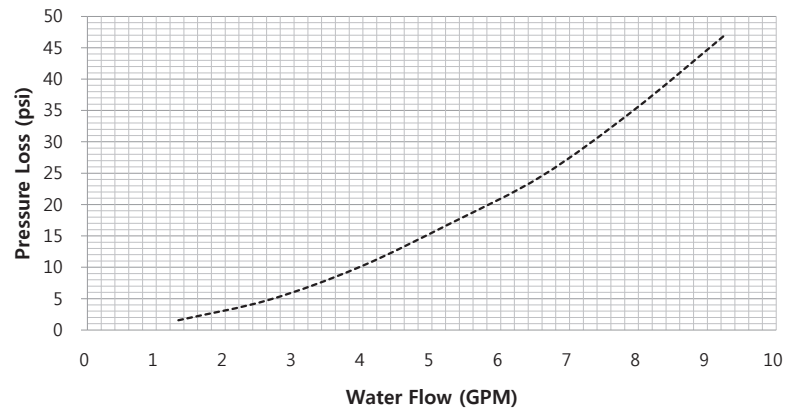

**[NPE-210A/ 210S]**

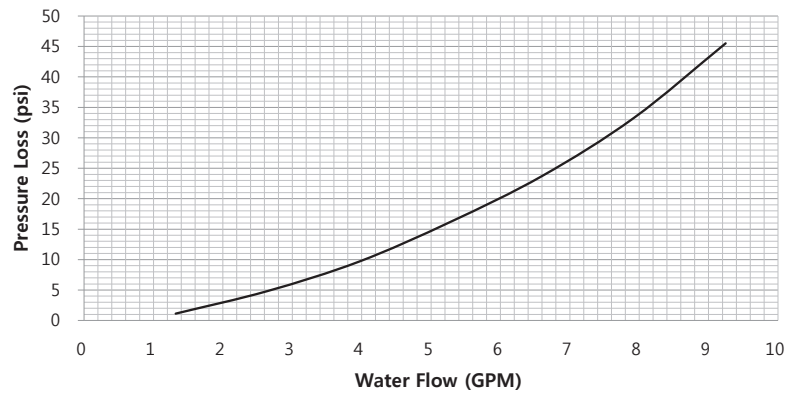

**[NPE-180A/ 180S]**

## Outlet Flow Data

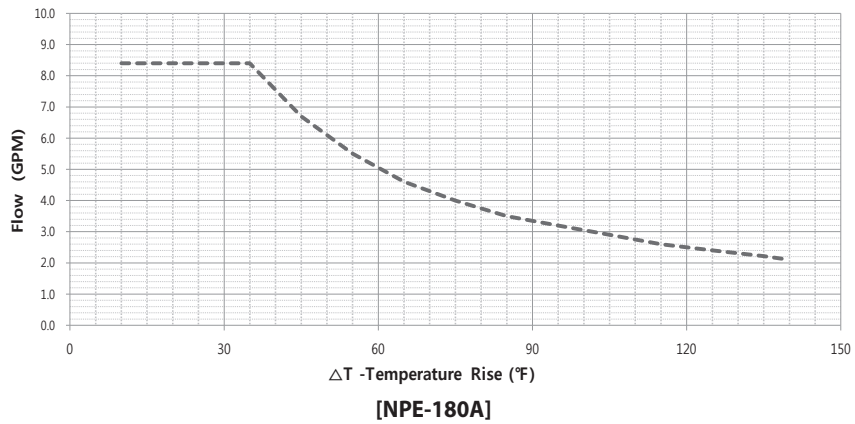
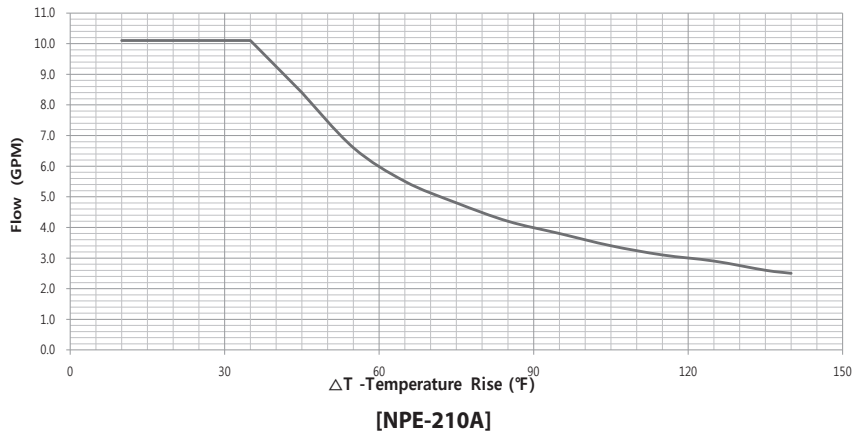
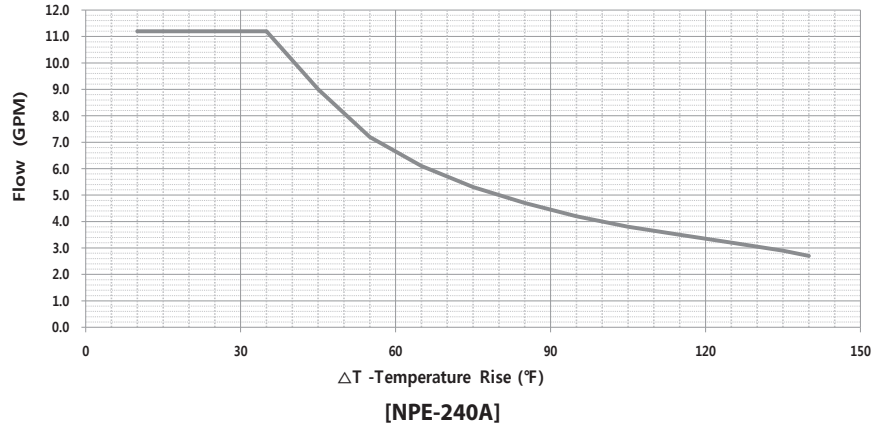

**Note**

At altitudes above 2,000 ft (610m), the outlet flow will be reduced by 4% for each 1,000 ft (305 m) of altitude gain.

## Outlet Flow Data

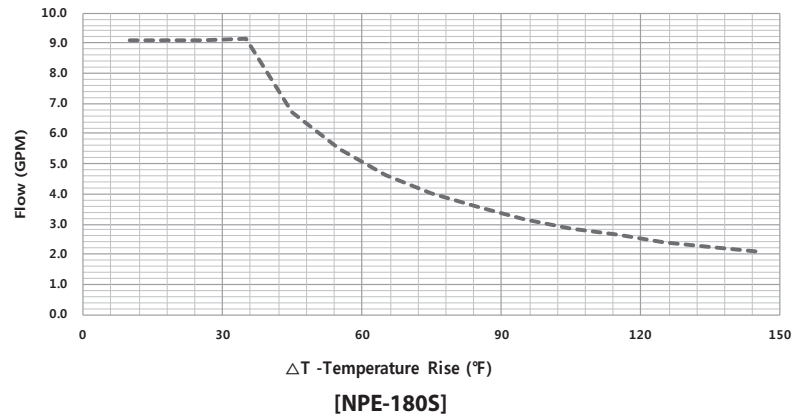
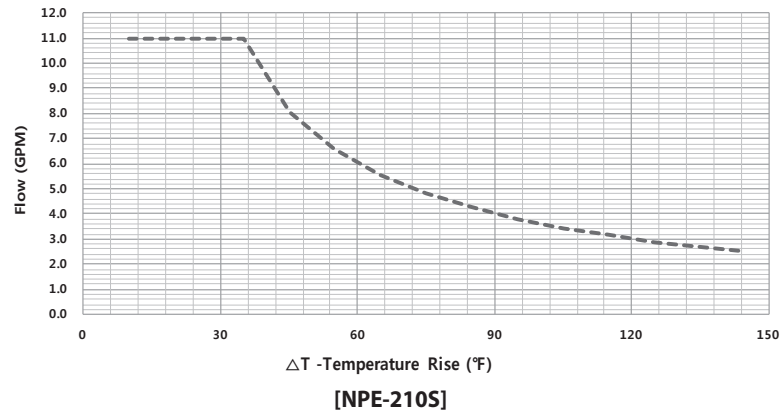
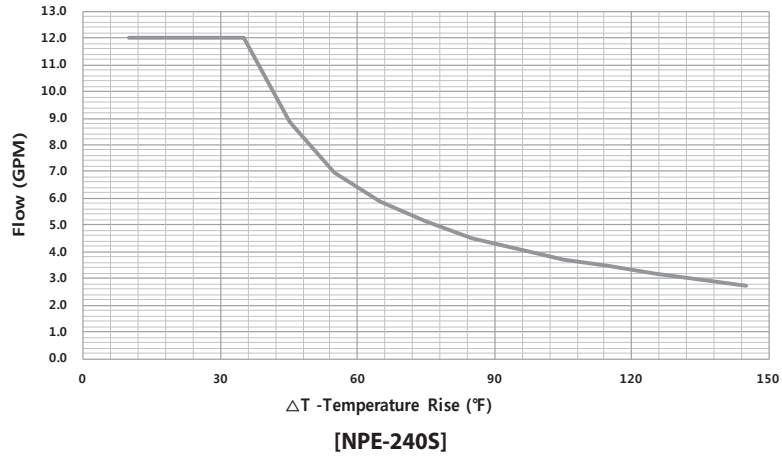

**Note**

At altitudes above 2,000 ft (610m), the outlet flow will be reduced by 4% for each 1,000 ft (305 m) of altitude gain.

### 5.3 Wiring Diagram

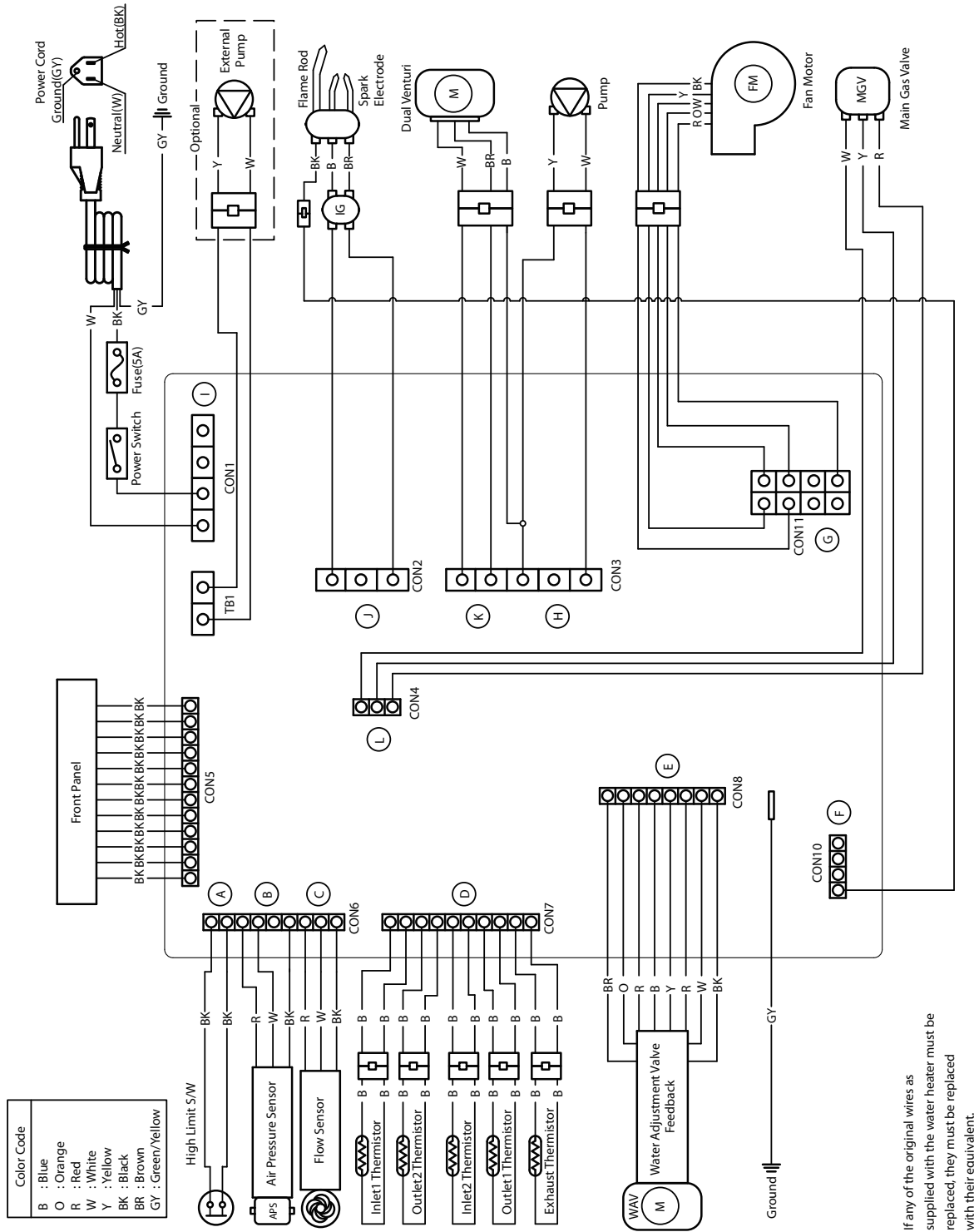

[NPE-180A/ 210A/ 240A]

If any of the original wires as supplied with the water heater must be replaced, they must be replaced with their equivalent.

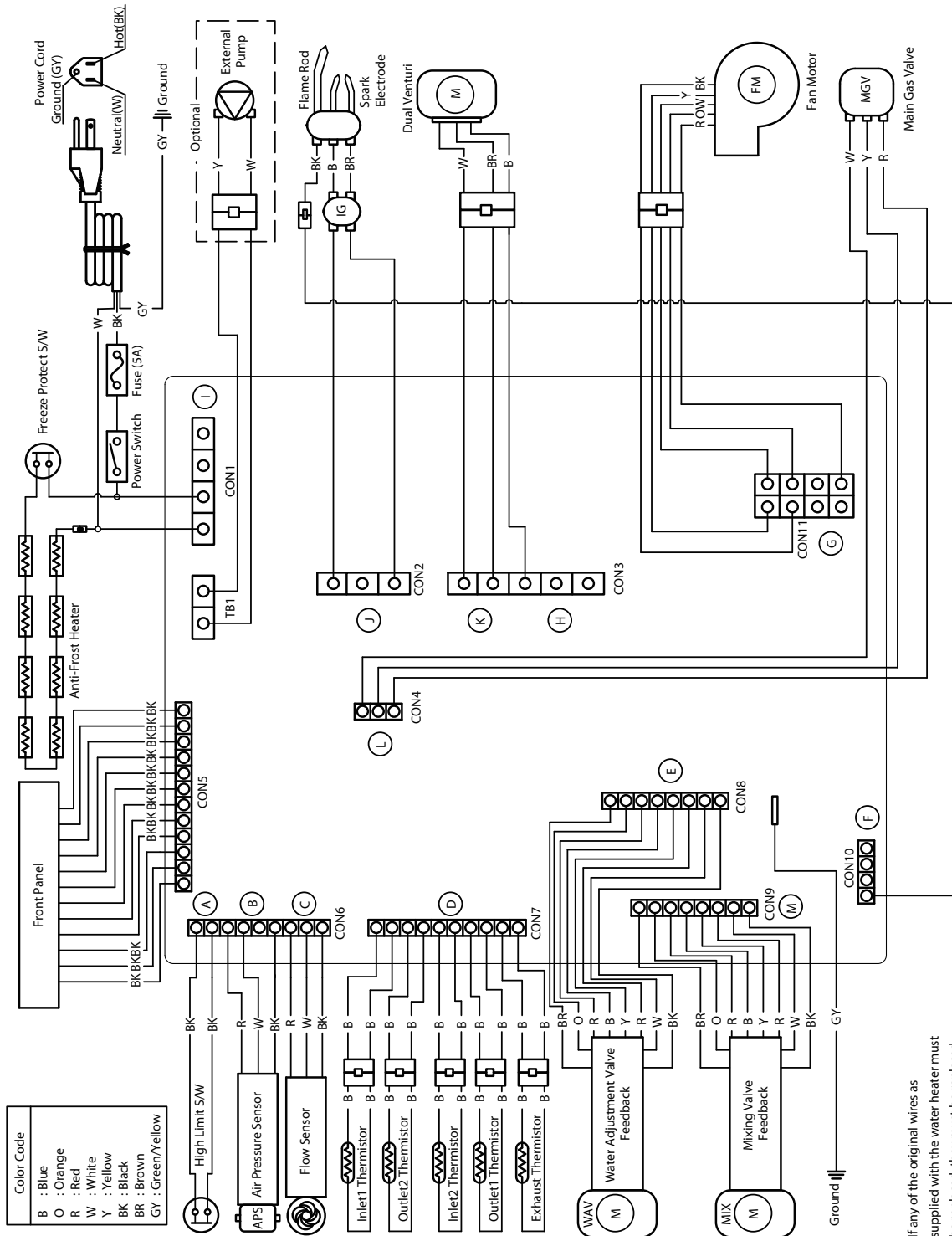

**[NPE-180S/ 210S/ 240S]**

If any of the original wires as supplied with the water heater must be replaced, they must be replaced with their equivalent.

## 5.4 Ladder Diagram

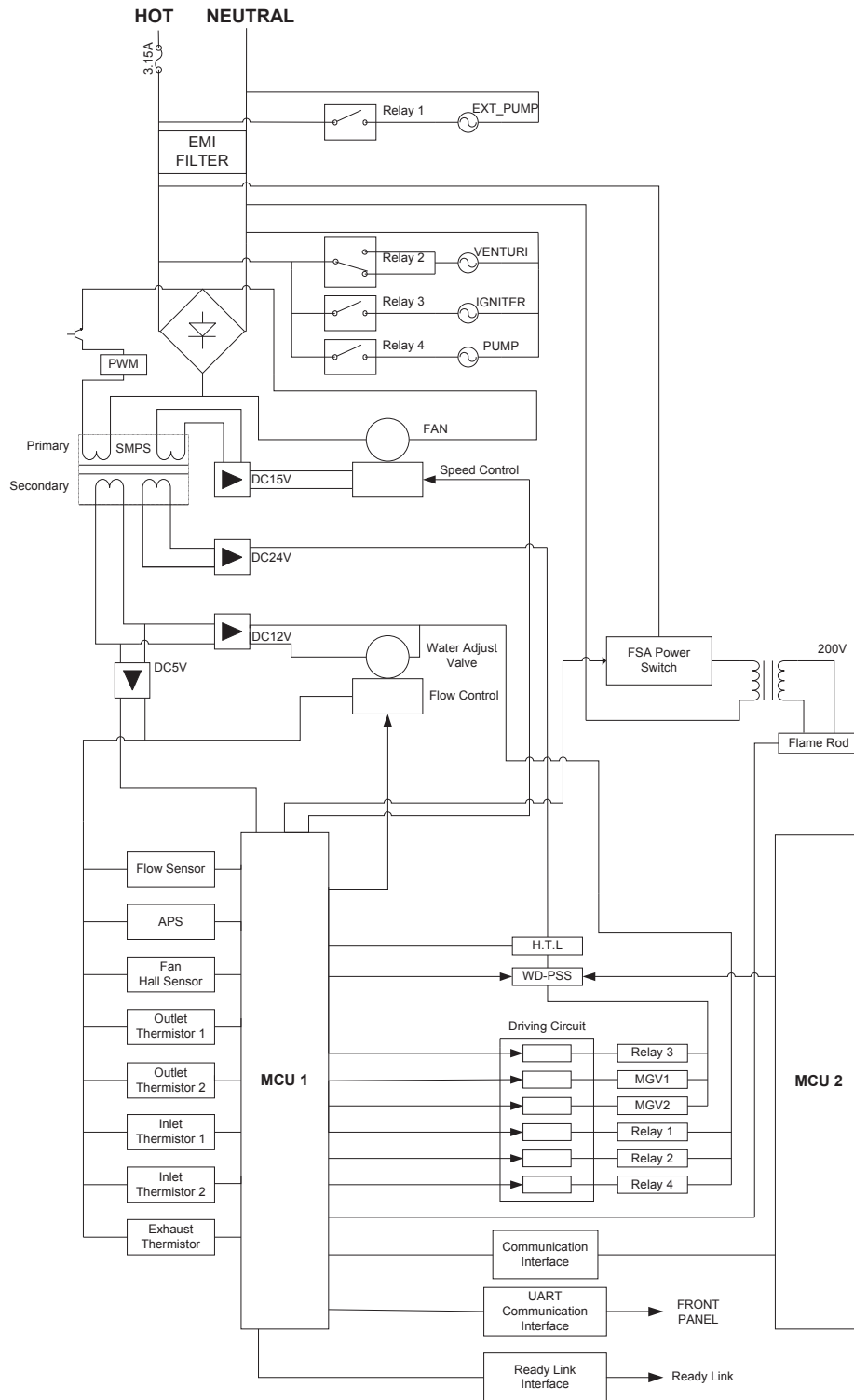

[NPE-180A/ 210A/ 240A]

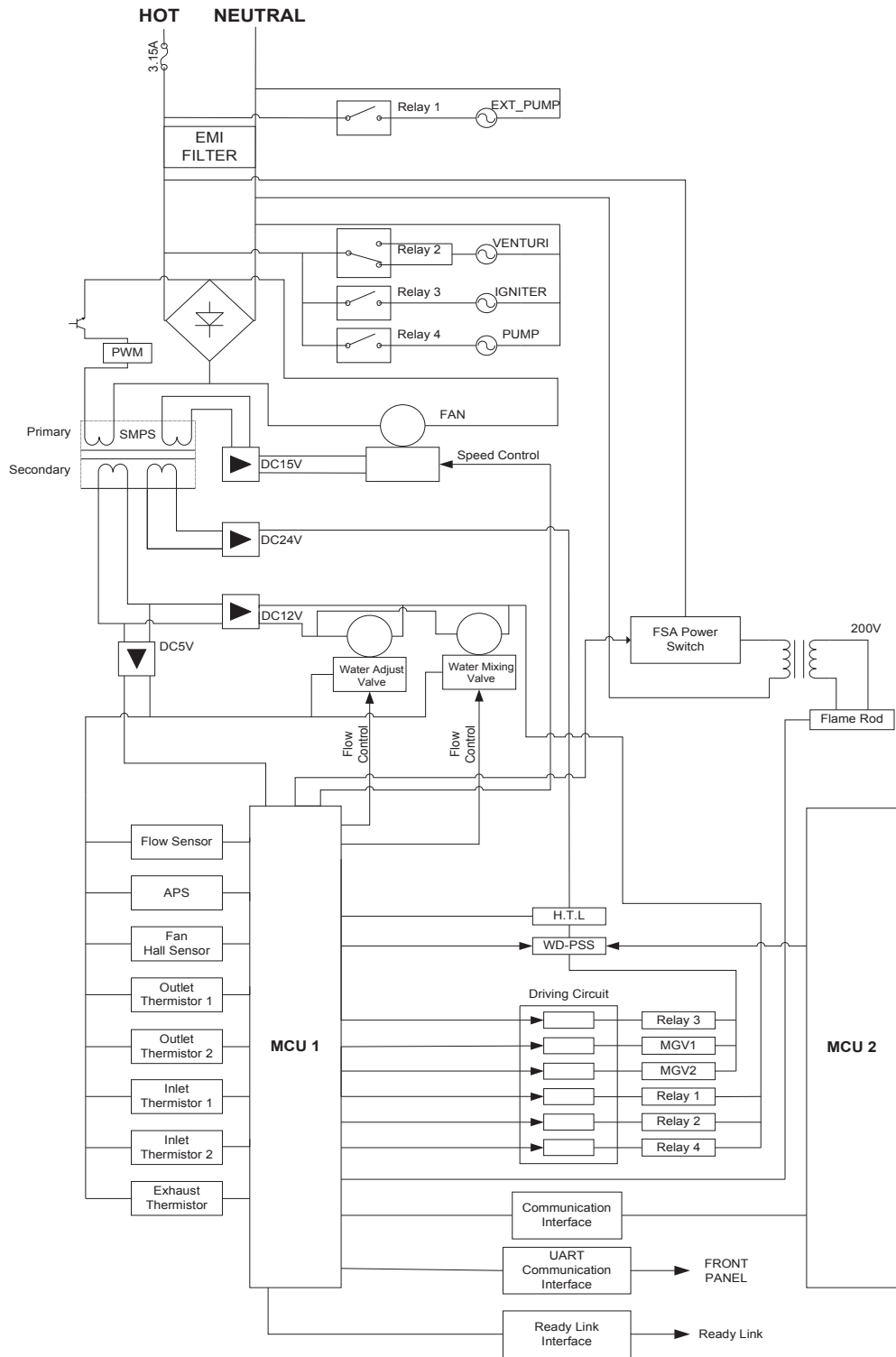

[NPE-180S/ 210S/ 240S]

## 5.5 Component Assembly Diagrams and Parts Lists

### 5.5.1 Case Assembly

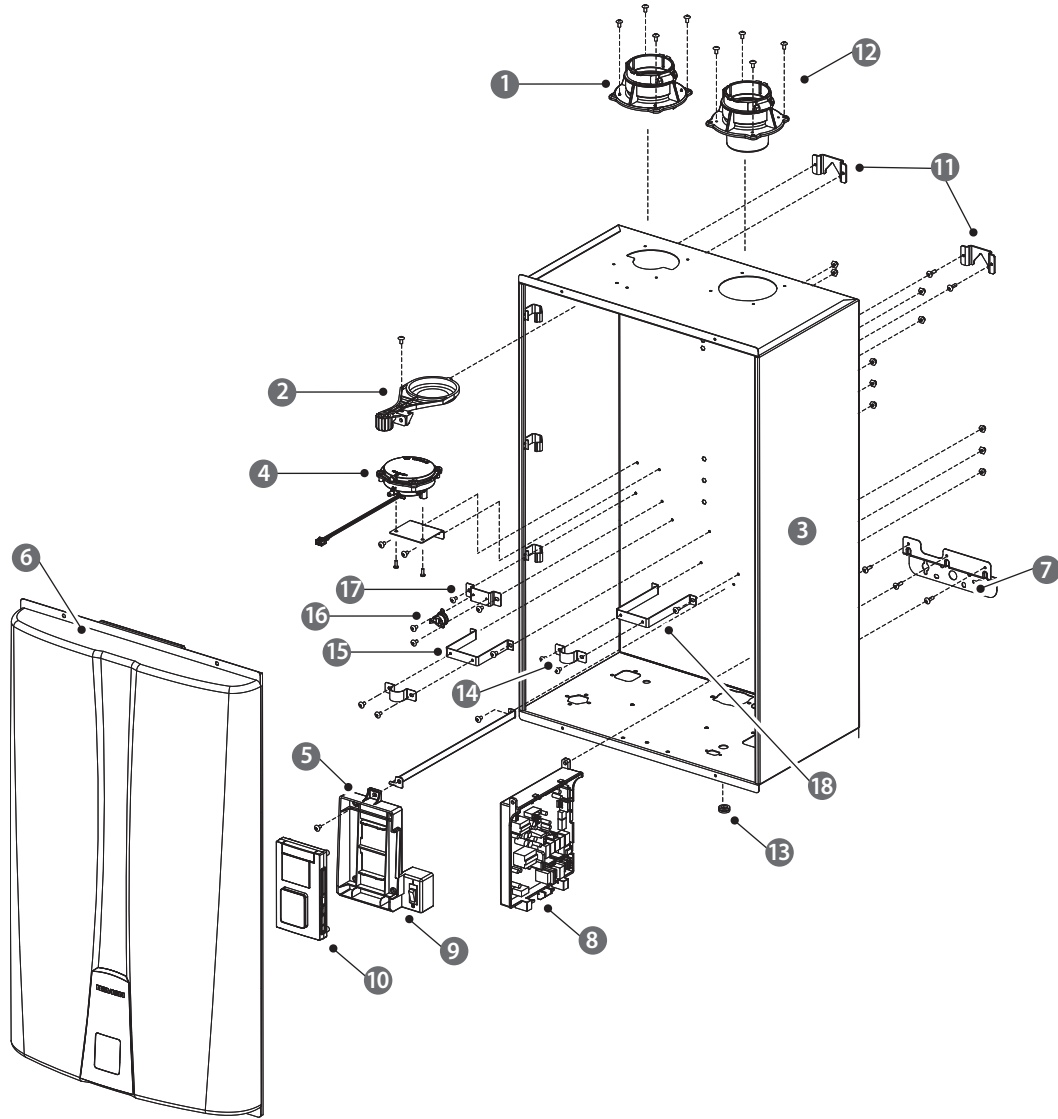

| #  | Description                     | Part #    | Remark             |
|----|---------------------------------|-----------|--------------------|
| 1  | Intake Air Duct Assembly        | 30008662A |                    |
| 2  | Intake Air Filter               | 30008745A |                    |
| 3  | Case                            | 20020393A | NPE-180A           |
|    |                                 | 20019078A | NPE-210A/240A      |
|    |                                 | 20026560A | NPE-180S           |
|    |                                 | 20026559A | NPE-210S/240S      |
| 4  | Air Pressure Sensor             | 30010346A |                    |
| 5  | Panel Bracket                   | 20018388A |                    |
| 6  | Cover                           | 30008678A | NPE-180A/210A/240A |
|    |                                 | 30011694A | NPE-180S/210S/240S |
| 7  | Case Lower Bracket              | 20007643B |                    |
| 8  | PCB                             | 30011969A |                    |
| 9  | Power Switch                    | 30009482A |                    |
| 10 | Front Panel                     | 30008333A |                    |
| 11 | Case Bracket                    | 20007609A |                    |
| 12 | Exhaust Pipe Assembly           | 30008673A |                    |
| 13 | Rubber Ring                     | 20006973A |                    |
| 14 | Saddle                          | 20013508A | NPE-180S/210S/240S |
| 15 | Saddle Bracket 1                | 20026170A | NPE-180S/210S/240S |
| 16 | Freeze Protector Sensor         | 30002587A | NPE-180S/210S/240S |
| 17 | Freeze Protector Sensor Bracket | 20007671A | NPE-180S/210S/240S |
| 18 | Saddle Bracket 2                | 20026172A | NPE-180S/210S/240S |

### 5.5.2 Burner Assembly(NPE-180A/ 210A/ 240A)

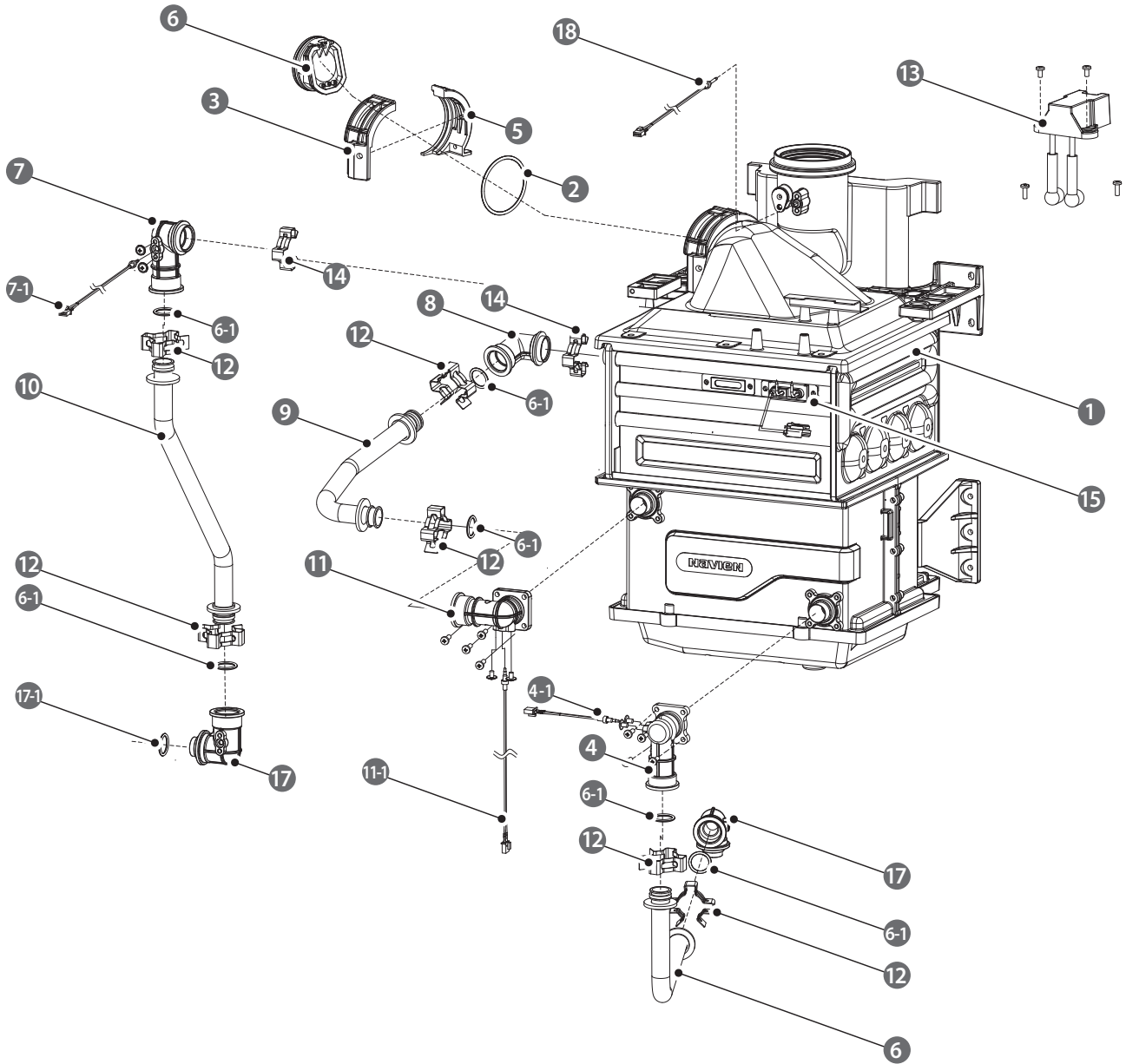

| #    | Description               | Part #    | Remark        |
|------|---------------------------|-----------|---------------|
| 1    | Heat Exchanger Assembly   | 30009189A | NPE-180A      |
|      |                           | 30010812A | NPE-210A      |
|      |                           | 30008780A | NPE-240A      |
| 2    | Fan O-Ring (G50)          | 20003019A |               |
| 3    | Fan Bracket(F)            | 20022095A |               |
| 4    | Flow Sensor Assembly      | 30008571A |               |
| 4-1  | Thermistor                | 30008366A |               |
| 5    | Fan Braket(R)             | 20022096A |               |
| 6    | Cold Inlet Pipe           | 30009166A | NPE-180A      |
|      |                           | 30010805A | NPE-210A      |
|      |                           | 30008446A | NPE-240A      |
| 6-1  | O-Ring (Φ17.5x2.7t)       | 20006947A |               |
| 7    | WPA-A (Clip)              | 20018344A |               |
| 7-1  | Thermistor                | 30008366A |               |
| 8    | WPA-B                     | 20018343A |               |
| 9    | H-Ex Middle Pipe          | 30009126A | NPE-180A      |
|      |                           | 30010803A | NPE-210A      |
|      |                           | 30008439A | NPE-240A      |
| 10   | Hot Water Outlet Pipe     | 30009145A | NPE-180A      |
|      |                           | 30008442A | NPE-210A/240A |
| 11   | WPA-A (Screw)             | 30008569A |               |
| 11-1 | Thermistor                | 30008366A |               |
| 12   | Fastner                   | 20017726A |               |
| 13   | Ignition Transformer      | 30010455A |               |
| 14   | Fastner                   | 20007853A |               |
| 15   | Ignitor                   | 30008591A |               |
| 16   | Damper                    | 30008825A |               |
| 17   | Buffer Tank Inlet Adapter | 20018346A |               |
| 17-1 | O-Ring(P16)               | 20017210A |               |
| 18   | Thermistor                | 30009478A |               |

5.5.3 Burner Assembly(NPE-180S/ 210S/ 240S)

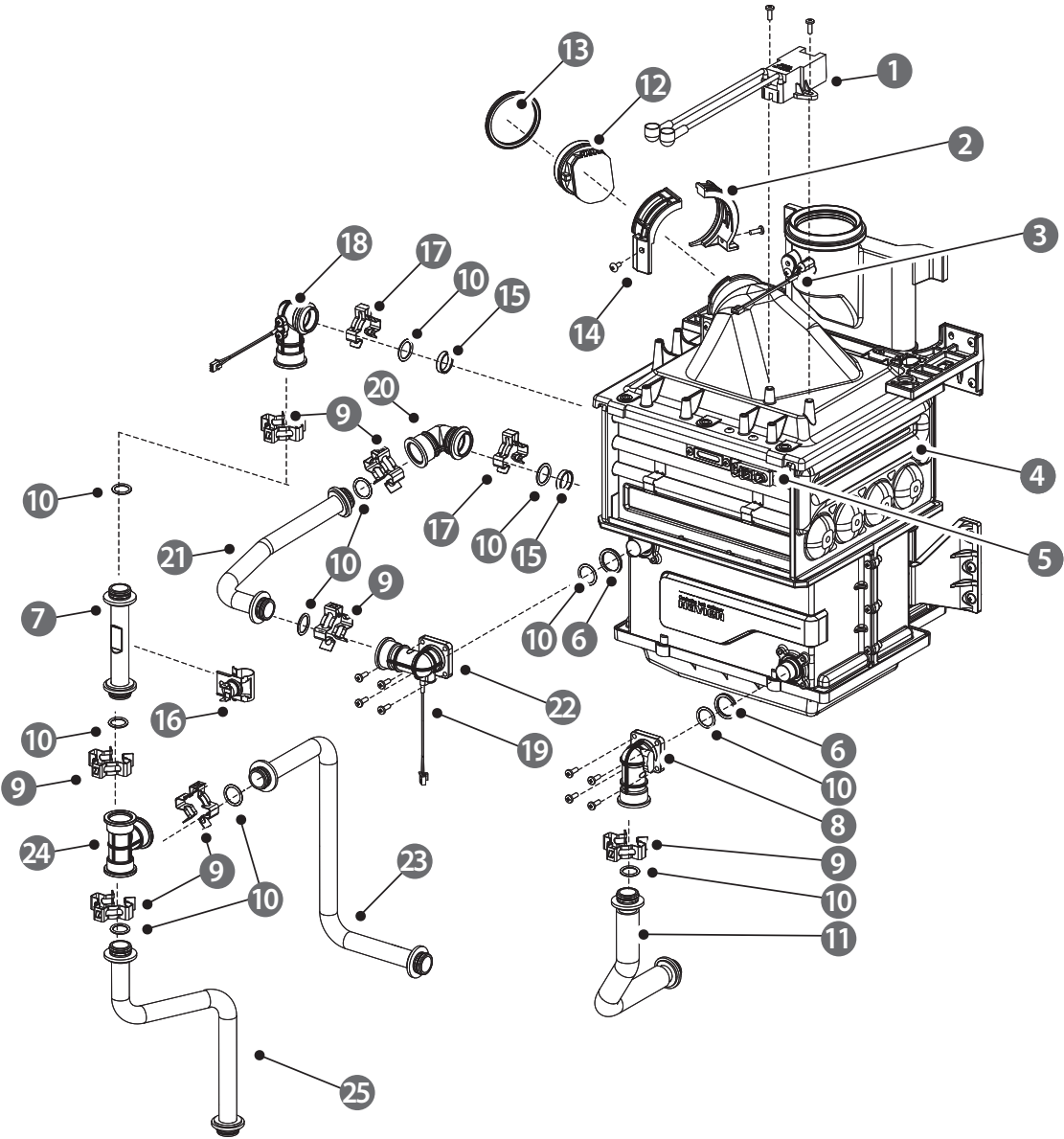

| #  | Description                | Part #    | Remark        |
|----|----------------------------|-----------|---------------|
| 1  | Ignition Transformer       | 30010455A |               |
| 2  | Fan Bracket (R )           | 20022096A |               |
| 3  | Thermistor                 | 30009478A | Exhaust       |
| 4  | Heat Exchanger Assembly    | 30011706A | NPE-180S      |
|    |                            | 30011705A | NPE-210S      |
|    |                            | 30011704A | NPE-240S      |
| 5  | Ignitor                    | 30008591A |               |
| 6  | Packing (Φ26.5x2.4t)       | 20006868A |               |
| 7  | Heat Exchanger Outlet Pipe | 30011519A | NPE-180S      |
|    |                            | 30011515A | NPE-210S/240S |
| 8  | WPA-C (Screw)              | 20026780A |               |
| 9  | Fastner                    | 20017726A |               |
| 10 | O-Ring (Φ17.5x2.7t)        | 20006947A |               |
| 11 | Cold Inlet Pipe            | 30011521A | NPE-180S      |
|    |                            | 30011665A | NPE-210S      |
|    |                            | 30011517A | NPE-240S      |
| 12 | Fan Damper                 | 30008825A |               |
| 13 | Fan Packing                | 20022744A |               |
| 14 | Fan Bracket (F)            | 20022095A |               |
| 15 | Backup Ring                | 20018744B |               |
| 16 | High Limit Switch          | 30002577A |               |
| 17 | Fastner                    | 20007853A |               |
| 18 | WPA-A (Clip)               | 20018344A |               |
| 19 | Thermistor                 | 30008366A | Water         |
| 20 | WPA-B                      | 20018343A |               |
| 21 | H-Ex Middle Pipe           | 30009126A | NPE-180S/180A |
|    |                            | 30010803A | NPE-210S/210A |
|    |                            | 30008439A | NPE-240S/240A |
| 22 | WPA-A (Screw)              | 30008569A |               |
| 23 | Mixing Pipe                | 30011518A | NPE-180S      |
|    |                            | 30011514A | NPE-210S/240S |
| 24 | WPA-T                      | 20025960A |               |
| 25 | Hot Water Outlet Pipe      | 30011520A | NPE-180S      |
|    |                            | 30011516A | NPE-210S/240S |

### 5.5.4 Waterway Assembly(NPE-180A/210A/240A)

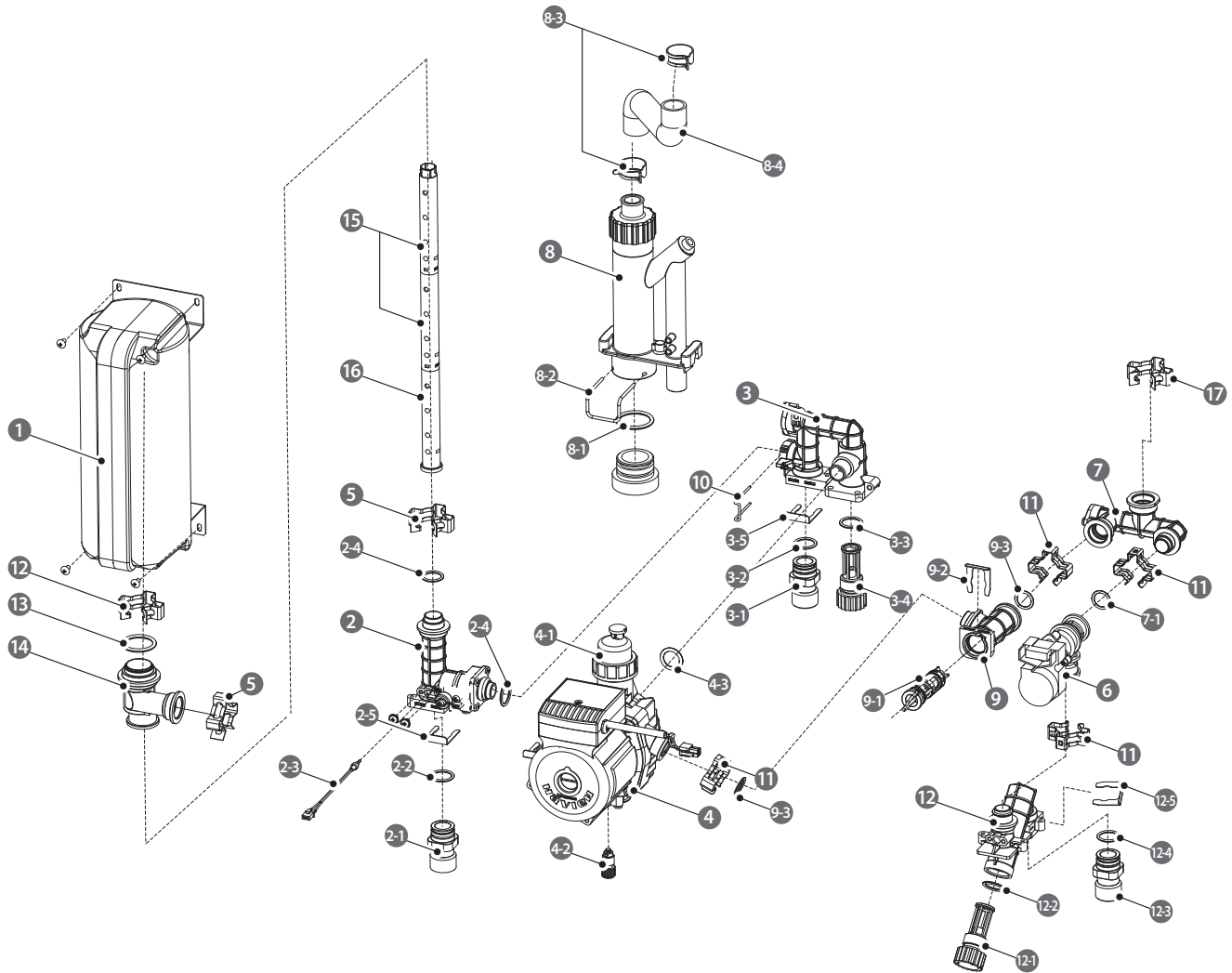

| #   | Description                    | Part #    | Remark |
|-----|--------------------------------|-----------|--------|
| 1   | Buffer Tank                    | 30010953A |        |
| 2   | Hot Water Outlet Pipe Assembly | 30008338A |        |
| 2-1 | Pipe Adapter                   | 30008349A |        |
| 2-2 | O-RING (P20)                   | 20017212A |        |
| 2-3 | Thermistor (Red)               | 30008366A |        |
| 2-4 | O-RING (P16)                   | 20017210A |        |
| 2-5 | Pipe Clip                      | 20007733A |        |
| 3   | Return Pipe Assembly           | 30008350A |        |
| 3-1 | Pipe adapter                   | 30008349A |        |

| #    | Description                    | Part #    | Remark |
|------|--------------------------------|-----------|--------|
| 3-2  | O-RING (P20)                   | 20017212A |        |
| 3-3  | O-RING (P19)                   | 20017211A |        |
| 3-4  | Water Filter                   | 30008351A |        |
| 3-5  | Pipe Clip                      | 20007733A |        |
| 4    | Circulation Pump               | 30010346A |        |
| 4-1  | Pump Air Separator             | 30006831A |        |
| 4-2  | Drain Plug                     | 30003550B |        |
| 4-3  | O-RING (P18)                   | 20006947A |        |
| 5    | Fastner                        | 20017726A |        |
| 6    | Water adjustment valve (WAV)   | 30008245A |        |
| 7    | WAV Outlet Pipe Assembly       | 30008624A |        |
| 7-1  | O-Ring (P16)                   | 20011438A |        |
| 8    | Syphon                         | 30009756A |        |
| 8-1  | O-Ring (Φ31.7x3.5t)            | 20018013A |        |
| 8-2  | Syphon Clip                    | 20018155A |        |
| 8-3  | Hose Clip                      | 20007833A |        |
| 8-4  | Syphon Hose                    | 20018429A |        |
| 9    | Pump Outlet Pipe Assembly      | 30008361A |        |
| 9-1  | Check Valve                    | 30008360A |        |
| 9-2  | Pipe Clip                      | 20017722A |        |
| 9-3  | O-Ring (P16)                   | 20017210A |        |
| 10   | Return Pipe clip               | 20017767A |        |
| 11   | Fastner                        | 20007859A |        |
| 12   | Cold Water Inlet Pipe Assembly | 30009437A |        |
| 12-1 | Water Filter                   | 30008351A |        |
| 12-2 | O-RING (P19)                   | 20017211A |        |
| 12-3 | Pipe adapter                   | 30008349A |        |
| 12-4 | O-RING (P20)                   | 20017212A |        |
| 12-5 | Pipe Clip                      | 20007733A |        |
| 13   | O-RING (P29)                   | 20017923A |        |
| 14   | Buffer Tank adapter            | 20017757A |        |
| 15   | Buffer tank pipe A             | 20017759A |        |
| 16   | Buffer tank pipe B             | 20017760A |        |
| 17   | Fastner                        | 20017724A |        |

### 5.5.5 Waterway Assembly(NPE-180S/ 210S/ 240S)

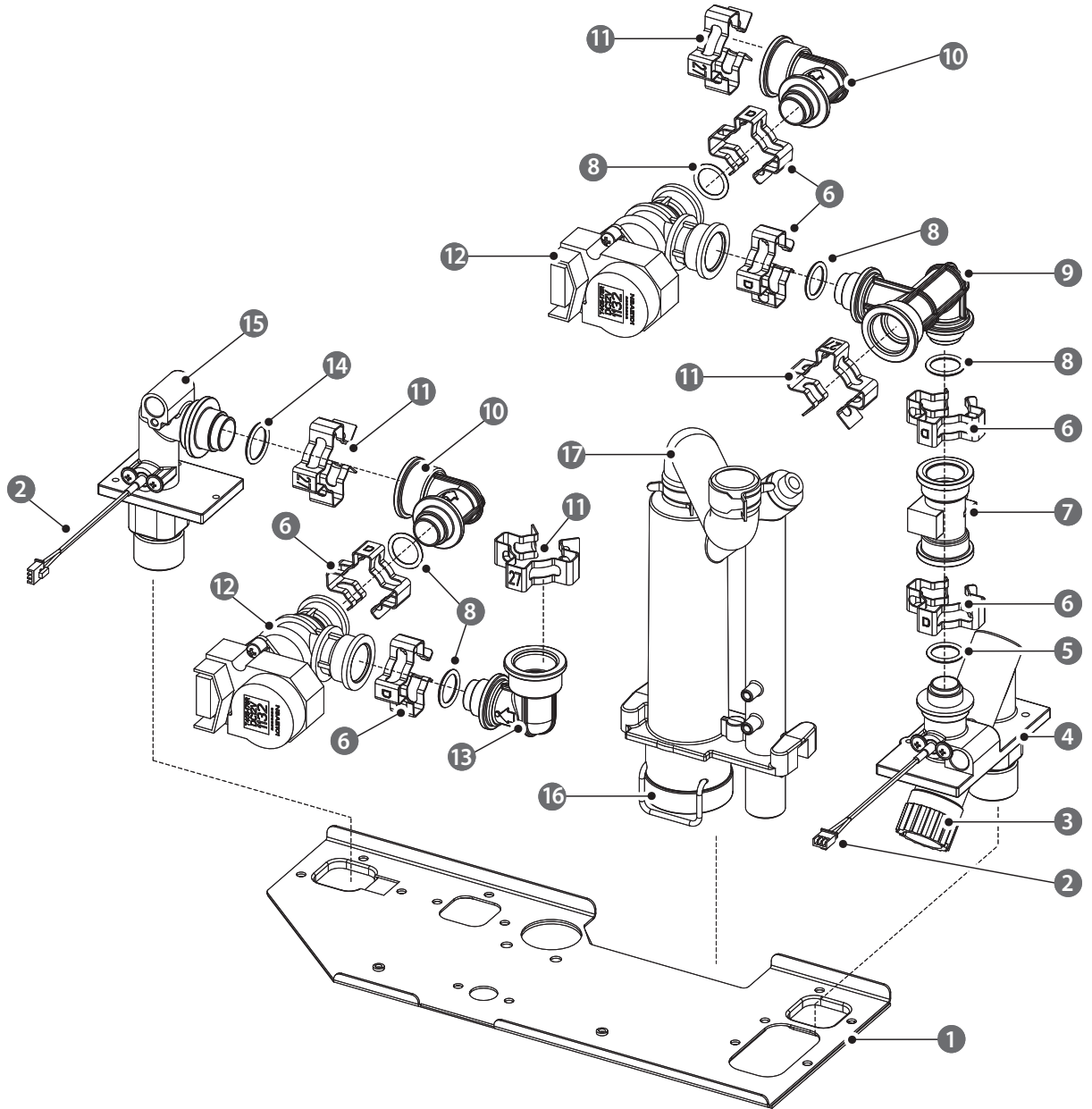

| #  | Description                  | Part #    | Remark |
|----|------------------------------|-----------|--------|
| 1  | Bracket                      | 20026489A |        |
| 2  | Thermistor                   | 30008366A |        |
| 3  | Water Filter                 | 30008351A |        |
| 4  | Cold Water Inlet Adapter     | 30011597A |        |
| 5  | O-Ring (P15)                 | 20017217A |        |
| 6  | Fastner                      | 20007859A |        |
| 7  | Flow Sensor                  | 30011534A |        |
| 8  | O-Ring (P16)                 | 20017210A |        |
| 9  | Flow Sensor Outlet Adapter   | 20025959A |        |
| 10 | Outlet Adapter               | 20025961A |        |
| 11 | Fastner                      | 20017726A |        |
| 12 | Water Adjustment Valve (WAV) | 30011532A |        |
| 13 | Inlet Adapter                | 20025962A |        |
| 14 | O-Ring (P18)                 | 20006947A |        |
| 15 | How Water Outlet Adapter     | 30011601A |        |
| 16 | Siphon                       | 30009756A |        |
| 17 | Siphon Hose                  | 20018429A |        |

### 5.5.6 Fan(Gas) Assembly

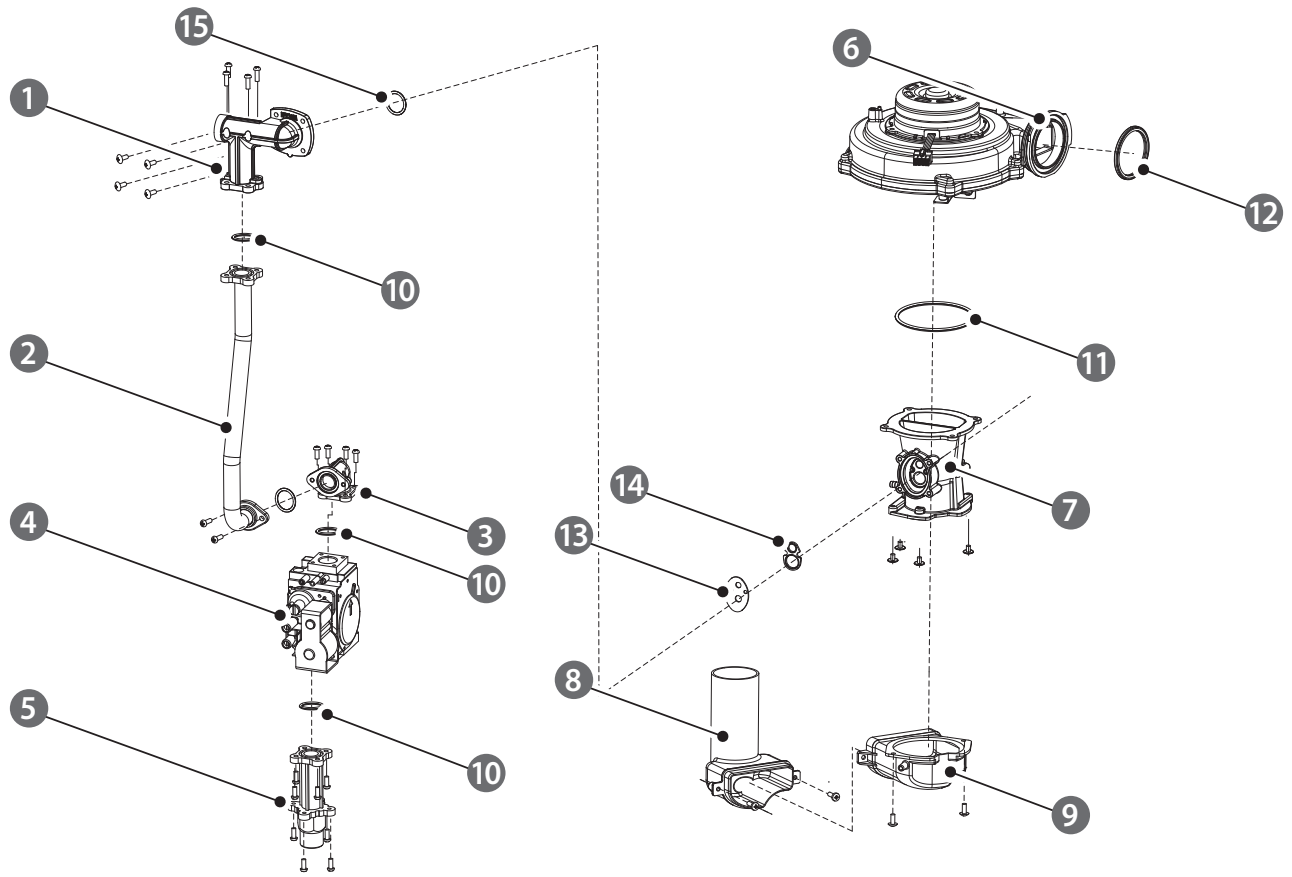

| #  | Description       | Part #    | Remark                       |
|----|-------------------|-----------|------------------------------|
| 1  | Gas Adapter       | 30008431A |                              |
| 2  | Gas Pipe          | 30009211A | NPE-180S/180A                |
|    |                   | 20018431A | NPE-210S/210A/240S/240A      |
| 3  | Gas Connector     | 20018430A |                              |
| 4  | Gas Valve         | 30008429A |                              |
| 5  | Gas Inlet Adapter | 30008382A |                              |
| 6  | Fan Assembly      | 30008834A |                              |
| 7  | Dual Venturi      | 30009219A | NPE-180S/180A                |
|    |                   | 30008909A | NPE-210S/210A/240S/240A      |
| 8  | Silence           | 20019142A | NPE-180S/180A                |
|    |                   | 20023829A | NPE-210S/210A/240S/240A      |
| 9  | Silence Adapter   | 20023861A | NPE-180S/180A                |
|    |                   | 20019141A | NPE-210S/210A/240S/240A      |
| 10 | O-Ring (P20)      | 20006934A |                              |
| 11 | O-Ring (G75)      | 20018079A |                              |
| 12 | Fan Packing       | 20022744A |                              |
| 13 | Gas Orifice       | 20024159A | NPE-180S/180A (LN)           |
|    |                   | 20024190A | NPE-210S/210A/240S/240A (LN) |
|    |                   | 20019144A | NPE-180S/180A (LP)           |
|    |                   | 20024189A | NPE-210S/210A/240S/240A (LP) |
| 14 | Venturi packing   | 20022660A |                              |
| 15 | O-Ring (P34)      | 20019090A |                              |

## 5.6 Installation Check list

After installing the water heater, review the following checklist. You should be able to answer "Yes" to all of the items in the checklist. If not, review the appropriate sections to complete the installation. To troubleshoot any operational problems refer to "Troubleshooting" in the Owner's Manual.

If you have additional questions or need assistance with installation, contact Technical Support at 1-800-519-8794 or 1-949-420-0420, or refer to the technical support section of Navien's website ([www.navienamerica.com](http://www.navienamerica.com)).

| Installing the Water Heater  | Yes | No |
|--|-----|----|
| Have you maintained the required clearances from building openings and intake air vents?                               |     |    |
| Have you minimized the distance between the water heater and the vent termination?                                     |     |    |
| Have you minimized the distance between the water heater and major fixtures?   |     |    |
| Have you maintained the proper service and maintenance clearances?   |     |    |
| Is the make-up air supply sufficient for proper operation?   |     |    |
| Is the make-up air supply free from dust, dirt, corrosive elements, and flammable vapors?                              |     |    |
| Is the water heater and vent piping clear of combustibile materials, including clothing, cleaning materials, and rags? |     |    |

| Connecting the Gas Supply  | Yes | No |
|--|-----|----|
| Does the gas supply match the type specified on the water heater's rating plate?       |     |    |
| Is the gas line at least 1/2" or 3/4" ID (Inner Diameter)?                             |     |    |
| Is the gas supply line sufficient in length and diameter to deliver the required BTUs? |     |    |
| Have you measured the pressure of the gas supply line?                                 |     |    |
| Is the gas supply pressure within the recommended ranges specified in this manual?     |     |    |
| Is the gas supply line equipped with a manual full port valve?                         |     |    |
| Have you tested the gas line pressure and all fittings for leaks?                      |     |    |
| Has the gas company inspected the installation, if required?                           |     |    |

| Connecting the Water Supply  | Yes | No |
|--|-----|----|
| Is the water supply pressure sufficient (greater than 40 PSI)?   |     |    |
| Have you installed shut off valves on the inlet and outlet to facilitate cleaning of the inlet water filter? |     |    |
| Have you bled the air out at each fixture?   |     |    |
| Have you checked each fixture to ensure hot water is being supplied?   |     |    |
| Have you cleaned the inlet water filter?   |     |    |
| If you installed a recirculation line, have you insulated the hot water pipes and the return line?           |     |    |

| Connecting a Pressure Relief Valve   | Yes | No |
|--|-----|----|
| Have you installed an approved pressure relief valve on the water heater?                                |     |    |
| Does the rating of the pressure relief valve match or exceed the maximum BTU rating of the water heater? |     |    |
| Is the pressure relief valve at least 3/4" in diameter?  |     |    |

| Connecting a Pressure Relief Valve   | Yes | No |
|--|-----|----|
| Have you installed the pressure relief valve on the hot water outlet pipe near the water heater?                   |     |    |
| Have you installed a discharge drain tube from the pressure relief valve to within 6-12" (150-300mm) of the floor? |     |    |

| Connecting the Condensate Drain   | Yes | No |
|---|-----|----|
| Have you installed a condensate drain line from the water heater to a drain or laundry tub? |     |    |

| Venting the Water Heater  | Yes | No |
|---|-----|----|
| Have you vented the water heater with 2" or 3" PVC, CPVC, Polypropylene, Type BH Special Gas Vent (ULC-S636) for Category IV Water Heaters (Canada), or in accordance with all local codes and the guidelines in this manual? |     |    |
| Have you ensured that PVC cellular core pipe has not been used as venting for the water heater?   |     |    |
| Is the vent sloped upward toward the vent termination at a rate of 1/4" per foot (2% grade)?  |     |    |
| Are all vent runs properly supported?   |     |    |
| Have you properly supported the vent termination?   |     |    |
| Have you properly sealed all air intake and exhaust joints, from the flue collar to the to the vent termination?  |     |    |
| Have you installed end caps on the exhaust and intake pipes?  |     |    |
| Have you checked the venting for leaks?   |     |    |
| Is the vent termination at least 12" (300mm) above the exterior grade?  |     |    |
| Have you ensured that sufficient make-up air is available?  |     |    |
| Is the total vent length within the maximum vent length restriction?  |     |    |

| Connecting the Power Supply  | Yes | No |
|--|-----|----|
| Is the supplied voltage 110-120V AC?   |     |    |
| Is the water heater plugged into a properly grounded outlet?   |     |    |
| If you have made a direct power supply connection, have you installed a power switch to facilitate end-user maintenance? |     |    |
| Have you checked the polarity of the electrical connection?  |     |    |
| Is the system properly set up for cascading operation (master and slave water heaters), if applicable?                   |     |    |

| Setting the DIP Switches  | Yes | No |
|---|-----|----|
| Have you verified the positions of all DIP switches on the circuit board? |     |    |
| Have you verified the positions of all DIP switches on the front panel?   |     |    |

| Operating the Water Heater   | Yes | No |
|--|-----|----|
| Have you shown the owner how to clean the inlet water filter?                                |     |    |
| Have you given the Installation Manual and Owner's Manual to the owner for future reference? |     |    |
| Have you shown the owner how to shut off the gas in case of an emergency?                    |     |    |

## Requirements for the State of Massachusetts

### NOTICE BEFORE INSTALLATION

This appliance must be installed by a licensed plumber or gas fitter in accordance with the Massachusetts Plumbing and Fuel Gas Code 248 CMR Sections 2.00 and 5.00.

IMPORTANT: In the State of Massachusetts (248 CMR 4.00 & 5.00)

For all side wall horizontally vented gas fueled equipment installed in every dwelling, building or structure used in whole or in part for residential purposes, including those owned or operated by the Commonwealth and where the side wall exhaust vent termination is less than seven (7) feet above finished grade in the area of the venting, including but not limited to decks and porches, the following requirements shall be satisfied:

1. **INSTALLATION OF CARBON MONOXIDE DETECTORS.** At the time of installation of the side wall horizontal vented gas fueled equipment, the installing plumber or gasfitter shall observe that a hard wired carbon monoxide detector with an alarm and battery back-up is installed on the floor level where the gas equipment is to be installed. In addition, the installing plumber or gasfitter shall observe that a battery operated or hard wired carbon monoxide detector with an alarm is installed on each additional level of the dwelling, building or structure served by the side wall horizontal vented gas fueled equipment. It shall be the responsibility of the property owner to secure the services of qualified licensed professionals for the installation of hard wired carbon monoxide detectors
  - a. In the event that the side wall horizontally vented gas fueled equipment is installed in a crawl space or an attic, the hard wired carbon monoxide detector with alarm and battery back-up may be installed on the next adjacent floor level.
  - b. In the event that the requirements of this subdivision can not be met at the time of completion of installation, the owner shall have a period of thirty (30) days to comply with the above requirements; provided, however, that during said thirty (30) day period, a battery operated carbon monoxide detector with an alarm shall be installed.
2. **APPROVED CARBON MONOXIDE DETECTORS.** Each carbon monoxide detector as required in accordance with the above provisions shall comply with NFPA 720 and be ANSI/UL 2034 listed and IAS certified.
3. **SIGNAGE.** A metal or plastic identification plate shall be permanently mounted to the exterior of the building at a minimum height of eight (8) feet above grade directly in line with the exhaust vent terminal for the horizontally vented gas fueled heating appliance or equipment. The sign shall read, in print size no less than one-half (1/2) inch in size, "**GAS VENT DIRECTLY BELOW. KEEP CLEAR OF ALL OBSTRUCTIONS**".
4. **INSPECTION.** The state or local gas inspector of the side wall horizontally vented gas fueled equipment shall not approve the installation unless, upon inspection, the inspector observes carbon monoxide detectors and signage installed in accordance with the provisions of 248 CMR 5.08(2)(a)1 through 4.

# *Memo*

---



# Installation Manual

## Getting Service

If your water heater requires service, you have several options for getting service:

- Contact Technical Support at 1-800-519-8794 or on the website: [www.navienamerica.com](http://www.navienamerica.com). For warranty service, always contact Technical Support first.
- Contact the technician or professional who installed your water heater.
- Contact a licensed professional for the affected system (for example, a plumber or electrician).

When you contact Technical Support, please have the following information at hand:

- Model number
- Serial number
- Date purchased
- Installation location and type
- Error code, if any appears on the front panel display.

Version: 3.00(April 30, 2013)

