

INTRODUCTION TO SPEARS® VALVES



Since 1969, Spears® Manufacturing Company has developed high quality thermoplastic piping system components to better meet industry needs. Spears® thermoplastic valves have been developed through years of product improvement testing, combined with the latest in computer aided engineering and manufacturing technology. Today, Spears® valves are recognized for their quality, reliability and long service life. Backed by the best in customer service and product availability, Spears® valves are the first choice for use in a wide variety of applications, including Industrial & Chemical Processing, Turf & Irrigation, Pool & Spa, and numerous Original Equipment Manufacture products.

Valve Function Basics

Ball Valves

Ball valves derive their name from the on/off function accomplished by means of a flow-controlling ball located in the center of the valve body. A hole through the center of the ball (valve bore) connects the inlet and outlet sides of the valve for fluid stream transfer. The ball rotates 90° on an axis perpendicular to the fluid stream in order to block flow in the “off” position. The ball is held in place between two valve seats, which serve as a “bubble tight” seal off, while providing lubrication during valve operation. Elastomer O-rings are used in the stem and seal carrier to prevent fluid leakage. Pressure drop is virtually eliminated in the full-open position, since the valve bore is the same size as Schedule 80 system piping. The T-Style ball valve is a special configuration incorporating a Tee fitting at one end of the valve. This design maintains close proximity of the valve to the fluid mainline to minimize “dead leg” of potential fluid accumulation, where required by specific application.

3-Way Ball Valves

3-Way ball valves are “diverter” style ball valves that provide an additional port to redirect the fluid stream. Valve configurations are either vertical (bottom branch port) or horizontal (side branch port). Multiple ball-port options are available in which different hole patterns in the valve ball provide alternative paths to divert flow. These diverter style 3-Way ball valves have no shutoff on the branch ports.

Check Valves

Check valves are automatic valves that open with forward flow and close with reverse flow. Exact operation will vary depending on the type of check valve mechanism. These include a ball (Ball Check), a swinging disc (Swing Check), a “double disc” (Butterfly Check), a weighted plug (Y-Check), and spring assisted types of check devices. These include a spring assisted swinging disc (Spring Check) and a spring mounted linear disc (In-Line Spring Check). Regardless of type, a check valve has a closure device positioned in the valve body between inlet and outlet so that the fluid stream is easily transmitted in the direction of flow, but is allowed to move against the check device in the event of flow in the reverse direction. Reversed flow is stopped or held in “check” by fluid backflow pressure which seats the closure device against the valve body. Standard elastomer O-ring seals are used in all Spears® Ball Check Valves and Industrial Swing Check Valves. Utility Swing and Spring Check Valves, and Butterfly Check Valves use an elastomer membrane seal; In-Line Spring Check Valves and Y-Check valves use an elastomer seat. Spears® Check Valves have been carefully engineered to minimize pressure drop and can be installed in either horizontal or vertical positions, within the limitations of the specific type of closure device. Ball Check Valves are well suited for general applications of fluids free from debris and entrained solids. Butterfly Check Valves have minimum space requirements and, along with Swing Check Valves, are better for use with fluids containing solids or debris. Swing Check Valves additionally allow higher volume of fluid transmission. Industrial Swing Check models can be fitted with an optional counter balance device to further control closing speed. The Utility Spring Check Valve (spring assisted Swing Check) aids in valve closing, while the In-Line Spring Check can be adjusted for resistance to opening pressure.

Swing Check Ball Valves

Swing check ball valves are a special design that combines the basic function of a ball valve and a swing check valve for use in general purpose applications where an in-line ball and check valve configuration is required



MATERIALS

Spears® Thermoplastic Piping System Materials

Benefits of Spears® Thermoplastic System Materials

Unlike metal, plastics never rust, scale, or pit — they virtually last forever. Thermoplastics are abrasion resistant, chemical and corrosion resistant, nonconductive, lightweight, and operate at lower friction-loss levels than metals. Moreover, plastics are nontoxic and environmentally safe. Adding these benefits with ease of installation at substantially lower costs, thermoplastic piping system components are the proven choice for years of maintenance free system operations.

Joining Methods for Spears® Thermoplastic Systems

Spears® thermoplastic piping system products are designed around primary components manufactured from PVC, CPVC or PP materials and their glass filled varieties. PVC and CPVC materials can be easily joined by solvent cement welding plus threaded, flanged or mechanical coupled connections. Spears® PP products are joined by using flanged or threaded connections featuring Spears® patented Special Reinforced (SR) female plastic threads.

Material Considerations in Application and System Design

PVC, CPVC and PP thermoplastic piping system components will give years of trouble free service with proper attention to application and system design. To avoid problems, the following key points must be considered when selecting materials for an application and in designing a system for their use.

- 1. Fluid incompatibility** of certain chemicals, especially petroleum distillates and derivatives, can cause environmental stress cracking in different thermoplastic compounds. Chemical compatibility of all valve or system components, including solvent cements, must be verified before installation. Verification of fluid compatibility is at the discretion of the user.
- 2. Temperature-pressure relationships** must be considered. Product pressure ratings are based on use of water mediums at 73°F. In general, product pressure ratings must be de-rated as temperature increases (see Temperature Pressure Table for individual valves).
- 3. Expansion and contraction** is greater in thermoplastic systems than in metal systems. As a result, system design must be flexible to allow for movement. Use of Spears® Thermoplastic Expansion Joints is recommended.
- 4. Extreme heat or cold** where internal fluids may freeze or where temperatures may exceed thermoplastic design limits must be avoided, including consideration of storage locations.
- 5. Direct sun exposure** results in high thermal heat absorption, especially in darker color thermoplastic materials. A white water-based exterior latex paint can be applied to reduce heat buildup.
- 6. Lower impact resistance** of thermoplastic system components than that of metal systems requires avoidance of sharp, pointed objects in both above and below ground installations, including mounting devices and backfilling operations.
- 7. Proper installation** is essential. Special attention must be given to technique and instructions for making solvent cemented connections, threaded connections, flanged connections, and for installation of valves and other individual system components. System design must also take into account support, thrust blocking, transition to different materials and other installation related factors.
- 8. Threaded joints** require several considerations. First, pressure capacities of threaded system components should be de-rated to 50% of the rating for corresponding type and size of thermoplastic pipe. *NOTE: Valves have individual pressure ratings and do not require de-rating for threaded connections.* Second, as with internal fluids, certain paste sealants may cause environmental stress cracking in thermoplastic materials, and compatibility should be verified before use. Finally, the leading cause of thread joint failures is from over tightening female thermoplastic threads. Use of Spears® Special Reinforced (SR) Threads is recommended.
- 9. Hydraulic Shock** (water hammer; surge pressure) in thermoplastic piping systems can burst pipe, fittings, and valves. Anticipated surge pressures should be calculated and included in maximum internal pressure ratings of system components (specified “Non-Shock” pressure rating for valves). Safeguards should be incorporated in system design to vent pressures and eliminate entrapped air. Fluid velocities should not exceed a maximum of 5 feet per second in thermoplastic systems.
- 10. Non-liquid transport** — **WARNING:** *Spears® Manufacturing Company DOES NOT RECOMMEND the use of thermoplastic piping products for systems to transport or store compressed air or gases, or the testing of thermoplastic piping systems with compressed air or gases in above or below ground locations. The use of Spears® products in compressed air or gas systems automatically voids Spears® warranty for such products, and their use against our recommendation is entirely the responsibility and liability of the installer. Spears® Manufacturing Company will not accept responsibility for damage or impairment from its products, or other consequential or incidental damages caused by misapplication, incorrect assembly, and/or exposure to harmful substances or conditions.*



Individual Materials Overview Thermoplastics

PVC — Poly Vinyl Chloride

PVC is one of the most specified thermoplastics for piping system components, including, valves, fittings, flanges, and many specialty products. PVC has excellent chemical and corrosion resistance to a broad range of fluids including water, deionized water, most mineral acids, bases, salts and paraffinic hydrocarbon solutions. PVC is not recommended for use with chlorinated or aromatic hydrocarbons, esters, or polar solvents such as ketones. Spears® PVC materials conform to ASTM Cell Classification 12454 (formerly designated as Type I, Grade 1). The maximum recommended service temperature of PVC products is 140°F (60°C).

Glass Reinforced PVC — Fiberloc®

Fiberloc® is a registered trademark of PolyOne Corporation. Fiberloc® is a glass fiber reinforced PVC composite material. While maintaining the traditional properties of PVC, Fiberloc® increases its strength, stiffness, and dimensional stability from glass fiber reinforcement. The maximum recommended service temperature of Fiberloc® products is 140°F (60°C).

CPVC — Chlorinated Poly Vinyl Chloride

Chlorinated PVC is used for higher temperature applications than PVC, especially for handling hot corrosive liquids. With similar chemical and corrosion resistance to PVC, increased chlorine content gives CPVC superior thermal resistance. CPVC is not recommended for use with chlorinated or aromatic hydrocarbons, esters, or polar solvents such as ketones. Spears® CPVC materials conform to ASTM Cell Classification 23447 (formerly designated as Type IV, Grade 1). The maximum recommended service temperature of CPVC products is 200°F (93°C).

Glass Reinforced CPVC

This special composite compound has the basic properties of CPVC with additional strength, stiffness, and dimensional stability from glass fiber reinforcement. The maximum recommended service temperature of glass reinforced CPVC products is 200°F (93°C).

PP — Polypropylene

Polypropylene is used in a variety of Spears® valves where different chemical resistance and lower temperature impact resistance is required as compared to PVC or CPVC. The excellent impact resistance characteristics of polypropylene make this polymer the choice for Spears® valve handles. Spears® PP products carry a maximum recommended service temperature of 180°F (82°C).

Glass Reinforced PP

Glass reinforced polypropylene is used in numerous valves and valve accessories where additional strength or stiffness is required over standard PP materials while maintaining basically the same range of chemical resistance.

PTFE / PFA (Teflon®) — Polytetrafluoroethylene / Perfluoroalkoxy Resin

Teflon® is a registered trademark of the DuPont Company. PTFE is a ram extrusion processed while PFA is a melt processed fluoroplastic. These fluoroplastics are virtually inert to most chemicals, acids bases and solvents. Due to their low coefficient of friction, these materials are considered “self-lubricating” making them an excellent choice for valve seats, bearings and thrust washers. Spears® proprietary processing of Teflon® with other materials allows low friction characteristics to be built into a variety of thermoplastic components used in Spears® valves. Fluoroplastics are serviceable to 500°F (260°C).

Teflon® HDPE

Spears® proprietary composition of Teflon® and High Density Polyethylene is used in a variety of valve seats, bearing washers, and other valve components requiring durability and improved lubricity. The chemical resistance of HDPE is somewhat higher than that of LDPE and generally exceeds that of PVC and CPVC. HDPE has excellent resistance to acids, alcohols and bases. In comparison to PVC and CPVC, HDPE is somewhat less resistant to aliphatic hydrocarbons and has more limited resistance to oxidizing agents. HDPE is serviceable to 230°F (110°C).

LXT™ (Low Extractable) PVC

LXT™ is a special PVC material developed for use in UPW (Ultra Pure Water) and other high purity applications. Independently tested, LXT™ PVC provides superior resistance to regular PVC for leaching of anion, cation, and numerous trace metals when subjected to 18.2 megohm deionized water while maintaining ease of installation. LXT™ has the same basic chemical resistance as regular PVC.

Elastomers

EPR (EPDM) — Ethylene propylene rubber

Used in O-ring seals, EPR is recommended for water, chlorinated water, dilute acids and alkalines, alcohols, and has excellent resistance to ozone. EPR is not recommended for petroleum oils, di-ester lubricants, strong acids, or strong alkalines. The maximum recommended service temperature of EPR is 300°F (149°C).



MATERIALS

FKM (Viton®) — Fluoroelastomer

Viton® is a registered trademark of DuPont-Dow Elastomers. Not all materials referenced as “VITON” are equal and may contain excess fillers or off-spec polymer. Spears® uses Type-A Viton® in O-rings and elastomer seals to insure optimum chemical resistance and performance. Viton® exhibits a very broad range of chemical resistance, including petroleum oils, di-ester based lubricants, silicate fluids and greases, halogenated hydrocarbons, and mineral acids. Viton® is not recommended for ketones, amines, anhydrous ammonia, hot hydrofluoric or chlorosulfonic acids, or automotive brake fluids. The maximum recommended service temperature of Viton® is 400°F (204°C).

Nitrile (Buna-N) — Nitrile elastomer

Used in O-ring seals, nitrile elastomers are recommended for petroleum oils and fluids, silicone oils and greases, di-ester based lubricants, ethylene glycol based fluids, and cold water. Nitrile is not recommended for phosphate ester hydraulic fluids, halogenated hydrocarbons, strong acids, ketones, ozone or automotive brake fluids. The maximum recommended service temperature of nitrile is 275°F (135°C).

FFKM (Aegis™, Kalrez®) - Perfluoroelastomer

Aegis™ is a trademark of ISC Freudenberg-NOK, Kalrez® is a registered trademark of DuPont-Dow Elastomers. These specialty materials are virtually inert and provide the greatest range of chemical resistance found in an elastomer. However, be aware that perfluoroelastomers are substantially more expensive than other elastomer compounds. Perfluoroelastomer are serviceable to 600°F (360°C) and performance is limited at very low temperatures.

CSM (Hypalon®) - Chlorosulfonated Polyethylene

Hypalon® is a registered trademark of DuPont-Dow Elastomers. CSM is a close match to neoprene, but it has improved chemical resistance. This specialty compound offers good abrasion resistance with superior resistance to weather, ozone, sunlight and oxidation. CSM has excellent resistance to alcohols, alkalis and acids, very good color stability with moderate resistance to oils and gasoline. CSM is not recommended for use with aromatic solvents. CSM has limited flexibility at low temperatures and relatively poor compression set. As a result, CSM is not generally manufactured as O-rings. CSM is serviceable to 300°F (149°C). Hypalon® is offered as an alternative diaphragm elastomer in Spears® Diaphragm Valves.

Teflon® Encapsulated O-rings

O-ring encapsulation places a Teflon® PFA or FEP material around a Viton® elastomer core to provide very high chemical resistance. However, this is not without a trade-off. The Teflon® encapsulation is far less resilient than an elastomer and may not perform as well in certain O-ring

applications. Teflon® encapsulated O-rings should be used only where an elastomers O-ring cannot meet requirements.

Elastomer Backed PTFE

Used in Spears® PTFE Diaphragm Valves, this chemically bonded laminate provides the chemical resistance of PTFE with improved resilience from a thick elastomer backing for greater sealing capability than solid PTFE Diaphragms. Use of heavier, high grade EPDM or Viton® backing materials eliminates the need for “gas barrier” PTFE Diaphragm designs.

Metals

Zinc Plated Steel

Zinc plated carbon steel is the standard for general purpose bolts, nuts and fasteners. Zinc plated steel provides good corrosion resistance for most dry environment applications and normal operating conditions.

Stainless Steel

Stainless Steel provides superior corrosion resistance than natural or plated carbon steels. Common grade is 18-8, which is excellent for general purpose use in nuts, bolts and fasteners. SS302 and SS304 are commonly used in a variety of sheet stock or deep drawn metal components. SS316 is the preferred choice for harsh chemical and corrosion environments and is used in the majority of Spears® industrial valves and accessories where stainless steel is required.

SS316 — Type 316 Stainless Steel

Used in special valve components, nuts, and bolts, SS316 is one of the highest chemical and corrosion resistant stainless steels available.

SS316L - Low Carbon Type 316 Stainless Steel

This specialty stainless steel provides extended chemical resistance over SS316 due to its lower carbon content. SS316L is used exclusively in all Spears® Butterfly Valve stems.

Teflon® Coated SS316L

Where very high chemical resistance is needed, Spears® offers a special Teflon® coated, low carbon type 316 stainless steel Butterfly Valve stem. This tough, chemically bonded coating makes the stem virtually inert to most chemicals without loss of function or reliability.

Special Alloys (Titanium, Hastaloy®, Alloy 20, etc.)

A variety of specialty metals can be obtained on a custom order basis for use in Spears® products where specific chemical or corrosion resistance is required and specified by user. Please note that custom components generally require extended lead-time and may have significant costs.

MATERIALS



Temperature Pressure De-rating for PVC, CPVC & PP Thermoplastic Materials

Elevated temperature fluid mediums require a de-rating of thermoplastic pipe maximum internal pressure ratings at 73°F. To determine the maximum internal pressure rating at an elevated temperature, simply multiply the pipe pressure rating at 73°F by the percentage specified for the desired temperature.

PLEASE NOTE — Valves have different elevated temperature ratings than pipe & fittings. See individual valve recommendations.

System Operating Temperature °F (°C)	73 (23)	80 (27)	90 (32)	100 (38)	110 (43)	120 (49)	130 (54)	140 (60)	150 (66)	160 (71)	170 (77)	180 (82)	190 (88)	200 (93)	210 (99)
PVC	100%	90%	75%	62%	50%	40%	30%	22%	-0-	-0-	-0-	-0-	-0-	-0-	-0-
CPVC	100%	100%	91%	82%	73%	65%	57%	50%	45%	40%	32%	25%	22%	20%	-0-
PP	100%	90%	75%	70%	65%	50%	42%	36%	30%	25%	20%	15%	-0-	-0-	-0-

Typical Physical Properties of PVC, CPVC & PP Thermoplastic Materials

The following table lists typical physical properties of PVC, CPVC and PP thermoplastic materials. Variations may exist depending on specific compound and product.

Properties	ASTM Test Method	PVC	CPVC	PP Natural*
Mechanical Properties, 73°F				
Specific Gravity	D 792	1.41	1.55	.907
Tensile Strength, psi	D 638	7,200	8,000	5,240
Modulus of Elasticity, psi	D 638	440,000	360,000	231,000
Compressive Strength, psi	D 695	9,000	10,100	---
Flexural Strength, psi	D 790	13,200	15,100	---
Izod Impact, notched, ft-lb/in	D 256	.65	1.50	3.02
Thermal Properties				
Heat Deflection Temperature, °F				
at 66 psi	D 648	165	217	201
Thermal Conductivity, BTU/hr/sq ft/°F/in	C 177	1.20	.95	
Coefficient of Linear Expansion, in/in/°F	D 696	3.1 x 10 ⁻⁵	3.4 x 10 ⁻⁵	5.42 x 10 ⁻⁵
Flammability				
Limiting Oxygen Index, %	D 2863	43	60	
UL 94 Rating		94V-0	V-0, 5VB, 5VA	HB
Other Properties				
Water Absorption, % 24 hr.	D 570	.05	.03	.02
Industry Standard Color		Dark Gray / White	Medium Gray	Natural/Beige
ASTM Cell Classification	D 1784/D 4101	12454	23447	PP0112 B65242
NSF Potable Water Approved		Yes	Yes	Yes

* Glass filled PP will have slightly different values with higher tensile strength.



STANDARDS

Spears® Valve Standards

Standards provide greater assurance of product performance and consistency, and are available to assist design engineers in system specification. The most frequently referenced industry standards for plastic piping systems are ASTM Standard Specifications and Practices. Along with ASTM Standards, additional product specifications and certifications form the basis of product conformance to which Spears® valves are manufactured.

Individual Standards Overview

ASTM — American Society for Testing and Materials

ASTM D 1784

Specifies compound physical requirements for PVC and CPVC materials used in the manufacture of thermoplastic valves, pipe, and fittings. The standard classifies compounds on the basis of several physical and chemical properties. Conformance to a particular material classification requires meeting the minimum requirements specified.

ASTM D 1785 and F 441

Specifies physical dimensions, test requirements, and maximum operating pressures, for Schedule 40, 80 and 120 PVC (D 1785) and CPVC (F 441) pressure pipe.

ASTM D 2466 and F 438

Specifies physical dimensions, test requirements, and workmanship for Schedule 40 PVC (D 2466) and CPVC (F 438) pressure fittings.

ASTM D 2464 and F 437

These standards have been incorporated into ASTM D 2467 and F 439, respectively.

ASTM D 2467 and F 439

Specifies physical dimensions, test requirements, and workmanship for Schedule 80 PVC (D 2467) and CPVC (F 439) pressure fittings.

ASTM D 2564, F 493, and F 656

Specifies requirements for PVC (D 2564) and CPVC (F 493) solvent cement, including component compounds, minimum resin content, viscosity, and physical performance. Standard F 656 specifies requirements for primers to be used with PVC solvent cements.

ASTM D 2846

Specifies physical dimensions, test requirements, and workmanship for CPVC Hot-and-Cold Water Distribution Systems, commonly referred to as CTS (Copper Tube Size).

ASTM D 2855

Specifies standard practice and procedures for making PVC pipe and fitting joints with solvent cement.

ASTM D 4101

Specifies classification of injection molding and extrusion grades of Polypropylene (PP) materials according to physical characteristics. Conformance to a particular material classification requires meeting the minimum requirements specified.

ASTM F 1498

Specifies dimensions and gauging of tapered pipe threads on plastic pipe and fittings.

ASTM F 1970

Specifies performance criteria testing, and end connection dimensions for products such as ball valves and check valves.

ANSI — American National Standards Institute

ANSI B1.20.1

Specifies basic thread form, taper, and tolerances of general purpose tapered pipe threads (metal).

ANSI B16.5

Specifies standard bolt hole patterns and basic dimensions for Class 150 steel pipe flanges.

NSF — National Sanitation Foundation

NSF is a third party product approval agency which tests manufacturer's product against a variety of health and product performance standards. They are one of the most recognized agencies for issuing approval of plastic piping system products for potable water use.

NSF Standard 14

Certifies product suitability for potable water use, product conformance to applicable ASTM standards, and establishes minimum requirements for manufacturer's quality control programs through routine testing and facilities inspections.

NSF Standard 14 Special Engineering Appurtenance Program (S.E.)

In addition to Standard 14 general requirements, the S.E. program establishes product performance requirements where no directly applicable ASTM specifications exist. NSF S.E. specifications are developed from a combination of applicable portions of ASTM specifications and manufacturer's design specifications as a standard for conformance verification.

NSF Standard 61

Developed to establish minimum requirements for the control of potential adverse health effects from products in contact with drinking water. Certifies product suitability for use in potable water systems through toxicological testing for contaminants or impurities. NSF Standard 61 compliance is a prerequisite to NSF Standard 14 certification.



UTILITY BALL VALVES



PVC



CPVC

Sample Engineering Specification

All thermoplastic ball valves shall be Utility sealed unit type constructed from PVC Type I, ASTM D 1784 Cell Classification 12454 or CPVC Type IV, ASTM D 1784 Cell Classification 23447. All O-rings shall be EPDM. All valves shall have Safe-T-Shear[®] stem and Polypropylene handle. All valves shall be certified by NSF International for use in potable water service. All valves shall be pressure rated at 150 psi for water at 73°F, as manufactured by Spears[®] Manufacturing Company.

Features - PVC White, PVC Gray & CPVC

A high quality, economical quarter-turn shutoff valve designed for irrigation, pool and spa, and general purpose applications. IPS sizes 1/2" - 2" available in PVC White, PVC Gray or CPVC with socket or threaded end connectors. Sizes 3" - 4" available in PVC White with socket or threaded end connectors. 6" size available in PVC White with socket end connectors and high-efficiency lever style handle for easier operation.

- Chemical & Corrosion Resistant PVC or CPVC Construction
- Economical Sealed Unit
- Schedule 80 Full-Bore Design
- High Impact Polypropylene Handle
- Spears[®] Single O-ring Safe-T-Shear[®] Stem Design
- EPDM O-rings
- Teflon[®] HDPE Floating Seat Design
- Sizes 1/2" - 6" Pressure Rated to 150 psi @ 73°F
- NSF Certified for Potable Water use
- Assembled with Silicone-Free, Water Soluble lubricant

Note: Valve sizes 2-1/2", 3", 4" and 6" are not available in CPVC. Refer to Compact Ball Valve
Valve size 6" uses Lever Handle (not shown)

Quick-View Valve Selection Chart

Valve Size	O-ring Material	PVC Part Number ^{1, 2}		Pressure Rating
		Socket	Threaded	
1/2	EPDM	2622-005	2621-005	150 psi Non-Shock Water @ 73°F
3/4	EPDM	2622-007	2621-007	
1	EPDM	2622-010	2621-010	
1-1/4	EPDM	2622-012	2621-012	
1-1/2	EPDM	2622-015	2621-015	
2	EPDM	2622-020	2621-020	
2-1/2	EPDM	2622-025	2621-025	
3	EPDM	2622-030	2621-030	
4	EPDM	2622-040	2621-040	
6	EPDM	2622-060	---	

1: For CPVC valves, add the letter "C" to part numbers listed (e.g., 2621-005C).
2: For PVC Gray, add the letter "G" to part numbers listed (e.g. 2621-005G).

UTILITY BALL VALVES

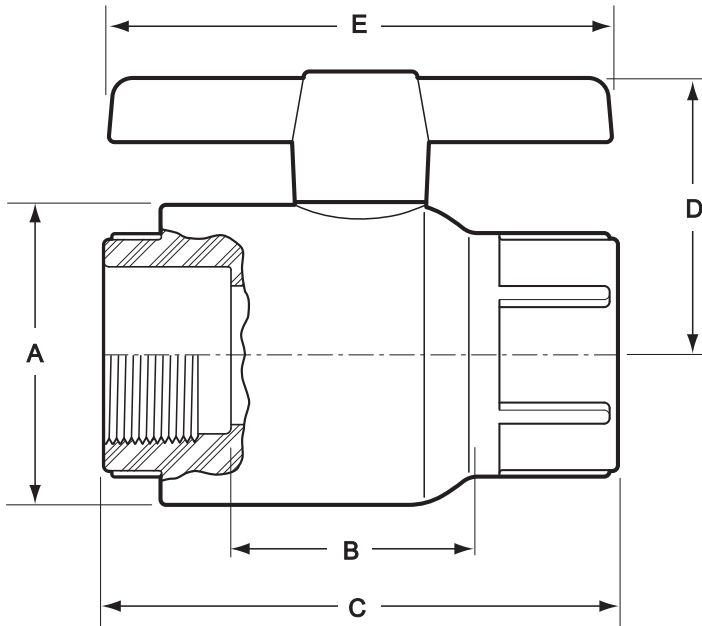

Dimensions, Weights & C_v Values

Nominal Size	Dimension Reference (inches, ± 1/16)					Approx. Wt. (Lbs.)		C _v ² Values
	A	B ¹	C	D	E ³	PVC	CPVC	
1/2	1-7/16	1-1/4	2-11/16	1-11/16	2-3/4	.16	.17	46
3/4	1-25/32	1-7/16	2-31/32	1-29/32	3-7/32	.25	.27	91
1	2-1/32	1-5/8	3-3/8	2-7/16	3-1/2	.34	.36	160
1-1/4	2-9/16	1-31/32	3-7/8	2-13/16	3-3/4	.57	.60	306
1-1/2	2-15/16	2-1/2	4-11/16	2-15/16	4-1/4	.88	.90	429
2	3-9/16	2-27/32	5-5/32	3-13/16	4-31/32	1.34	1.34	755
2-1/2	4-5/16	3-17/32	7-1/32	4-5/32	5-9/16	2.31	N/A	1126
3	5-5/16	4-19/32	8-11/32	5-9/16	7-21/32	4.78	N/A	1660
4	6-11/16	5-21/32	9-11/16	6-6/32	10-27/32	8.00	N/A	3129
6 ³	10-3/16	8-3/32	14-3/16	8-5/32	14-3/32	23.24	N/A	7942

1: Valve Lay Length
 2: Gallons per minute at 1 psi pressure drop. Values calculated from valve laying length, based on derivative of Hazen-Williams equation with surface roughness factor of C=150.
 3: 6" valve has lever handle, dimension is from valve stem centerline (not illustrated)

Temperature Pressure Rating

System Operating Temperature °F (°C)		73 (23)	100 (38)	110 (43)	120 (49)	130 (54)	140 (60)	150 (66)	160 (71)	170 (77)	180 (82)	190 (88)
Valve Pressure Rating psi (MPa)	PVC	150 (1.03)	93 (.64)	75 (.52)	60 (.41)	45 (.31)	33 (.23)	-0- (-0-)	-0- (-0-)	-0- (-0-)	-0- (-0-)	-0- (-0-)
	CPVC	150 (1.03)	123 (.85)	110 (.76)	98 (.68)	86 (.58)	75 (.52)	68 (.47)	60 (.41)	48 (.33)	38 (.26)	-0- (-0-)

NOT FOR USE WITH COMPRESSED AIR OR GASES